

INDUSTRIAL SOLUTIONS UK

www.solutionspublishing.co.uk  www.facebook.com/solutionsuknews  @Publishing_2016

LEADING LASER WELDING & LASER CLEANING TECHNOLOGY

Laser welding machines are used to join thin metal sheets with minimum heat input and the joining of differing metals, offering precision advantages for intricate designs and delicate materials.

see page 4



IN THIS ISSUE

Biopharma Group
see page 3

SubCtech
see pages 8-9

Interface Force
see pages 12-13

WJ Horrod
see page 17

Service Sealing Solutions
see pages 18-19

Arkem Leisure
see page 20

BUILDING UPDATE

Checkedsafe
see pages V-VII

Linear Motion Specialists

MOTION & CONTROL™

Authorised NSK & Nippon Bearing Distributor



RM Fowler Ltd

see page 5

Contents

Issue 684 • March 2024

Whats Inside



5

Biopharma Group
We Recommend



8-9

SubCtech
Ocean Power & Monitoring
Systems



14-15

UNISIG
Deep Hole Drilling



17

W J Horrod
75 Year Milestone in Industry



18-19

Service Sealing Solutions
Sealing Solutions



20

Arkem Leisure
Prefabricated Portable Buildings

BUILDING UPDATE



Checkedsafe
Compliance Solutions

V-VII



Playcraft Group
UK Manufacturers

VIII



Pandor
Bespoke Door & Panel
Manufacturing

X



DCON Safety
Safety Consultants

XII

On the Cover Machinery Supplies UK



4

Editors Comments

Hello & Welcome to Issue 684 of Industrial Solutions UK!

The team at Industrial Solutions UK has been working extremely hard to bring you an issue that is full of innovative and exhilarating companies and we are very excited to share their success and achievements with you.

We have searched the length and breadth of the UK to bring you some of the most ground-breaking innovations and this month, we are overjoyed to be highlighting the activities of Machinery Supplies UK and Checkedsafe.

Firstly, we would like to focus on the accomplishments Machinery Supplies UK who this month features on our front cover!

Secondly, we are featuring Checkedsafe celebrating '10 Years in the Industry' providing simple and inexpensive compliance solutions that could be tailored to any industry. These can be found in Building Update on pages V-VII.

I hope you enjoy reading this issue of Industrial Solutions as much as we have enjoyed bringing it to you. Happy reading and we hope to see you for the next edition!

Ian Hayward, Editor
INDUSTRIAL SOLUTIONS UK

Contacts

Editorial
Ian Hayward, Editor
T 0121 241 8788
info@solutionspublishing.co.uk

Accounts
Accounts Manager
T 0121 681 0935
accounts@solutionspublishing.co.uk

Production
Production Manager
T 0121 241 8788
production@solutionspublishing.co.uk

Industrial Solutions UK is based on the belief that our customers needs are of the highest priority and the utmost importance, with this in mind our team of highly dedicated staff work around the clock to make sure that those needs are always met.

For more information or format requirements, please see our [Media Pack](#).

For all advertising & sales enquiries, please contact Ian Hayward on: **0121 241 8788**, email: info@solutionspublishing.co.uk or visit: www.solutionspublishing.co.uk

FIND US ON:



Sponsored by  on page 4

DO YOU KNOW THAT BIOPHARMA GROUP OFFERS *Ultra* PRODUCTION FREEZE DRYERS

WITH CUSTOMISABLE CONFIGURATIONS,
SUITABLE FOR CLEANROOMS & ASEPTIC GMP FACILITIES?



Used extensively in
ISO 13485 environments,
our range of freeze dryers from
ATS LIFE SCIENCES SCIENTIFIC PRODUCTS,
already has a proven track record you can trust

CONTACT A PRODUCT SPECIALIST

VISIT

www.biopharma.co.uk

Machinery Supplies UK Ltd

Leading laser welding and laser cleaning technology

Laser welding machines are used to join thin metal sheets with minimum heat input and the joining of differing metals, offering precision advantages for intricate designs and delicate materials.

During 2023, the global laser welding machine market grew exponentially to \$1.32 billion from \$1.26 billion the year before, with a projected growth of \$1.55 billion by 2027. Europe has seen the biggest share of the market, closely followed by growing interest across the Asia-Pacific region.

There is increasing global demand for fabricated metal products in the renewable energy sector (wind turbine manufacturing), automotive (engine parts to injectors), aerospace, medical, electronics sectors (circuit boards, transistors and integrated circuits) and jewellery/the arts.

With a focus on the circular economy and Net Zero Targets, laser welding provides pinpoint accuracy, which means higher quality welds and less waste.



Spotlight on Machinery Supplies UK Ltd: Laser welding experts

Laser welding is a game-changer, offering welding up to four times faster than TIG welding, with significantly greater safety assurances due to reduced splatter and debris.

Established in 2020, Machinery Supplies UK Ltd was founded by Andy Naylor, who brings a wealth of industrial sheet metal experience spanning over 35 years. Based in East Yorkshire, Andy regularly travels to China to source the world's best laser welding machinery from high-end manufacturers to sell to clients in the UK, Europe, USA and Taiwan.

Laser welding: The future is here

Laser welding is ten times faster than conventional welding, which is good news for capacity and high demand in sectors like wind turbine manufacturing. The new Labour Government has removed restrictions on on-shore wind turbine planning and plans to deliver 50GW of offshore wind by 2030. This translates to the building of 2,600 wind turbines at the cost of £48 million by 2030 alone. Due to its geographical location, the UK has more capacity for offshore wind power generation compared to any other country in the world, except China. Laser welding offers hugely advantageous benefits to welding across the wind turbine manufacturing sector, which in turn will transform the UK's renewable energy sector.

Contact us today for the latest available fiber lasers

We have meticulously tested all duty cycles and penetration levels and they are all coupled with auto single or double wire feed, with water-cooled refrigerant, with superior components like refrar laser

guns and maxphotonics. Our latest upgrades have nozzle changes to allow laser weld cleaning functions.

We can provide all information on machinery requirements, have a full UK stock of spares and consumables, expert welding technician phone support and arrange delivery as required and our laser cleaning technology is second to none.

Laser cleaning technology

Laser cleaning technology is used in variety of applications, to remove rust, paint, oxide and other contaminant like graffiti - with no damage to materials, due to its eco-friendly properties. This is an industry game-changer that substitutes sand blasting and other ways of cleaning metals. Traditional industrial cleaning methods are labour-intensive and some paint removal by sandblasting has caused permanent damage to the metal beneath.

Endnote on Laser welding

Laser welding is used for welding components made from high-strength alloys in aerospace, creating precise joins in surgical instruments in medical science, is integral to wind turbine manufacturing and many more applications. It is transforming manufacturing, repair and design on a global scale.

Visit the East Yorkshire showroom today!

For more information, contact Andy Naylor on the details below:

T 01482 420491

T 07743 989565

info@ukmachinery.uk

https://ukmachinery.uk

https://www.linkedin.com/in/andy-n-629859a0

https://twitter.com/usedmach

QUALITY FABRICATION MACHINERY



We offer full UK support and training

- Laser Welding
- Laser Cleaning
- Laser Engraving
- Laser Cutting
- Laser Accessories/Slat Cleaners
- Breakout Hammers - Magnet Lifters
- Pressbrakes - Shears - Punching
- UK Stock Consumables - UK Engineers



Please visit: machinesupplies.co.uk

M. 07743 989565 | T. 01482 420491 | E. info@ukmachinery.uk



Safeguard your Production Freeze Drying Process with Equipment from Biopharma Group

For critical applications in cleanrooms, aseptic GMP facilities, and ISO 13485 environments, trust production freeze dryers available from Biopharma Group across the UK, Ireland and France that have been designed and developed by ATS Scientific Products, to meet your production needs for the lyophilization segment of your sample or product processing. Our proven track record delivers unparalleled reliability and regulatory compliance.

Biopharma Group, a leading capital lab equipment supplier, offers a complete portfolio of **ATS Scientific** freeze dryers for full scalability from benchtop models up to full pharma and biotech production models for aseptic GMP and/or non-aseptic environments. These industry-standard systems are renowned for:

- **Advanced Aseptic Processing:** Designed for sterile environments, minimising contamination risks.
- **GMP Compliance:** Ensures adherence to strictest pharmaceutical manufacturing guidelines.
- **ISO 13485 Adherence:** Meets rigorous quality management standards for medical devices.



- **Scalability:** Accommodates diverse production volumes, from small batches to large-scale needs.
- **Expert Support:** Biopharma Group's specialists provide comprehensive support, from selection to installation and ongoing maintenance.

Contact Biopharma Group's specialists today to discuss your requirements and discover how our production freeze dryers can elevate your product processing to safeguard your product integrity and accelerate your time to market.

T +44 (0)1962 841092
bps@biopharma.co.uk
www.biopharma.co.uk

ECO PHYSICS AG develops new three-channel chemiluminescence analyser (NO/NO₂/NH₃)

ECO PHYSICS AG offers innovative analytical solutions for measurement tasks in the fields of environment, health and process control.



Using its vital expertise and technology to contribute towards environmental preservation, human health, and industrial innovation, ECO PHYSICS' interdisciplinary research and development team work tirelessly to deliver the best customer orientated and tailor-made products and services for the industry.

Knowing there is no quick fix to economic changes, ECO PHYSICS is determined to continue innovating and has developed a new three-channel analyser based on chemiluminescence. As an upgrade from the The nCLD AL2, The nCLD3/8555 CY analyser is the next generation in high precision nitrogen oxide measurement. Unique in speed and reliability, the nCLD3/8555 CY is modular designed and capable of simultaneously NO, NO₂, NO_x, NH₃ and NOX-Amines. The new and intuitive graphical

user interface also individually displays and connects to other instruments' data.

Overall stability and reliability are lifted to a new level. The optional electro-mechanical bypass system balances out even the fastest of pressure variations occurring in the sample flow. Furthermore, the analyser is adaptable to numerous non-standardised applications and the calibration of the unit runs quickly and automatically with all necessary data available anywhere at any time. Its user friendly, compact, modular, and intelligent hosting its own CPU whilst enabling interaction with other CPUs by BUS-communication.

Going forward, ECO PHYSICS is excited to continue working on optimising production workflow whilst simultaneously expanding its current portfolio and developing new technologies.

T +41 55 220 22 22
info@ecophysics.com
https://www.ecophysics.com

Controls, Drives & Automation

Linear Motion Specialists



Authorised NSK & Nippon Bearing Distributor



RM Fowler Ltd

- High precision linear guides and ball screws
- NSK K1 lubricating units to extend maintenance intervals
- NH series available with high temperature design
- RA roller guides for high load, rigidity and precision
- PU/PE Miniature series with high corrosion resistance
- Precision cross roller non-recirculating slide ways
- Slide bush, Topball, Stroke bush and Ball splines
- Precision curved cross roller Gonio Ways

01565 651 051
 sales@rmfowler.co.uk
 www.rmfowler.co.uk



Oliver Valves expands testing capabilities with new in-house hydco cycle rig



Oliver Valves has announced a significant investment in its R&D and testing capabilities with the introduction of a new in-house hydco cycle rig. This advanced system is designed to automatically test up to four ball valves simultaneously, enhancing the company's ability to ensure product quality and reliability.

The new hydco cycle rig is equipped with pneumatic actuators that operate with precision, offering the capability to handle valves with torque up to 82.3Nm and withstand extreme temperatures ranging from -40°C to +80°C. These features allow for comprehensive testing that closely replicates real-world conditions, ensuring that the valves can meet the

demanding requirements of various global industries.

Enhancing valve testing precision The system's automated valve testing capabilities mark a significant improvement in the efficiency and accuracy of Oliver Valves' testing processes. With the ability to test four valves at once, the rig reduces manual intervention while increasing throughput.

Additionally, two of the testing stations are equipped with sensors that measure crucial data points such as pressure drops, temperature fluctuations, and the correct opening and closing of valves. The system's alarms automatically stop the test if any parameter exceeds the acceptable range, preventing damage and recording each valve's cycle data.

With this cutting-edge system in place, Oliver Valves continues to lead in the design, engineering, and manufacturing of high-performance valves, supplying industries across the globe with the robust solutions they require.

T +44 (0)1565 632636
sales@valves.co.uk
<https://www.valves.co.uk>

Take sound to the cloud with Quantum from Cirrus Research

For more than five decades, health and safety practitioners have turned to noise monitoring equipment such as handheld sound level meters and personal noise dosimeters to assess noise levels in the workplace. However, with more and more businesses choosing to operate from multiple sites as opposed to across one site, it's possible that these more traditional methods of noise measurement and monitoring may no longer be the most efficient.

Quantum; the future of noise measurement

Quantum Indoor from Cirrus Research is a powerful noise monitoring solution with built-in cloud connectivity, perfect for continuous occupational noise monitoring, identifying the source and type of noise that is occurring, and highlighting where noise control measures are required.

With this instrument, it has never been easier to measure and monitor workplace noise continuously and remotely across one or multiple sites.



The cloud technology that is built into the Quantum instruments allows health and safety practitioners to connect multiple noise monitors on one account, allowing for data from each noise monitor to be viewed and assessed on one platform. This creates a network of interconnected instruments, whose data can be viewed and analysed side-by-side, removing the need to download information from separate handheld instruments one-by-one.

Contact
T +44 (0)1723 891655
sales@cirrusresearch.com
www.cirrusresearch.com

Hoists

Construction hoists with top-class service

Direct Hoist, is an ever-expanding construction hoist hire and sales specialist, with an unrivalled attitude towards impeccable safety standards and a green revolution within the industry sector.

With a specialist team of hoist experts, Direct Hoist offers cost-effective construction solutions and no-nonsense advice, keeping your costs down and productivity high.

Specialising in Electroelsa and GEDA hoists, which have lifting capacities from 200kg to 5,000kg, Direct Hoist's fastidiously-maintained fleet is available for sale or hire throughout the UK.

Installation and dismantling is handled by a highly-qualified team – all SSSTS-certified, holding NVQ Level 2 Blue or Level 3 Gold CSCS cards.

Direct Hoist's company founder and managing director Rob Wilson, is keen to ensure customers can benefit from his firm's growth by gaining access to not just a wider range of products but a one-stop shop for planning, supply and tuition for the use of construction hoists.

One of Direct Hoists' larger hoists on the hire fleet is the Electroelsa PM23, a goods and personnel hoist with a rack and pinion system



that revolutionises material and personnel lifting on site. Featuring a 1,500 – 2,300kg lifting capacity to heights up to 220m, this hoist has an independent overspeed device (OSD) and safety systems that prevent overloading. It also has a missing mast bolts detector and Electroelsa's remote fault-finding diagnostics to reduce downtime. The PM23 is ideal where space is limited, installation is possible within demolished stairwells or areas set up for permanent lifts. The interchangeability of the components, such as different-sized platforms, offers maximum versatility for all kinds of construction site requirements.

Rob says, "We've been in this industry for over 30 years, working face-to-face with many varied and valued clients. This means we intuitively know exactly what each customer needs for every project – how to make life easier, saving time and construction costs. In turn, they can trust our experience and advice to be the absolute best."

So confident is Rob that Direct Hoist offers the best packages, his company gives free advice and site surveys; crucially, his team assesses what might



be needed later in the scheme to ensure the right equipment is provided from the outset.

Direct Hoist takes you up in the world with top-class construction hoists for any commercial project. For your free advice and site survey call: 01724 781647 or for more information about these or other hoists available for sale or hire, hoist servicing and repairs, please visit: www.directhoist.co.uk, or email: info@directhoist.co.uk.

Monitoring your environmental impact couldn't be easier!

With Quantum Outdoor from Cirrus Research.

Get instant access to your **noise, weather, air quality and ground vibration data** with Quantum Outdoor from Cirrus Research, our first fully integrated cloud-based comprehensive environmental monitoring system.

Quantum Outdoor can work in any environment, including providing long-term remote noise and environmental monitoring for the construction and demolition industry.

Discover remote environmental monitoring:
cirrusresearch.com/quantum-monitoring

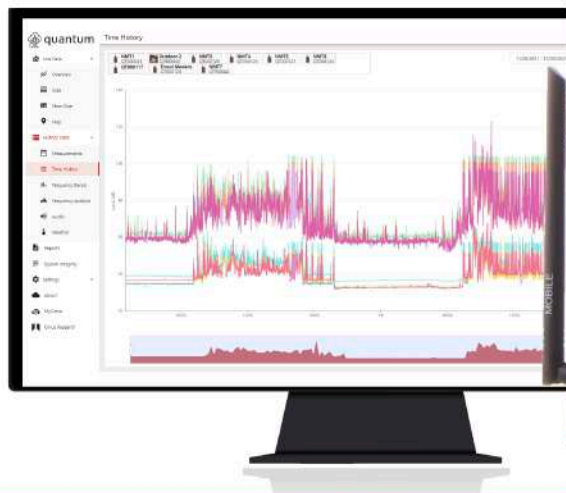

Innovative Technologies and Sustainable Measurement Strategies for the Marine Environment

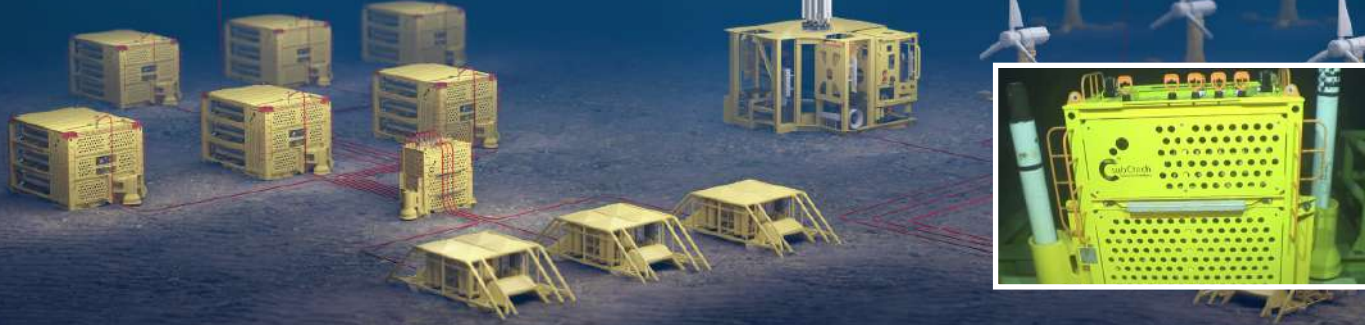

In this issue of Industrial Solutions, we are happy to feature award-winning SubCtech (Subsea Technologies for the Marine Environment) a leading manufacturer of underwater technologies for its Commitment to Excellence in Ocean Power and Monitoring Systems.

Established in 2010 by Applied Physicist: Stefan Marx (CEO), the maritime powerhouse is based in Kiel, Northern Germany. With a diverse team of expert mechanical and electrical engineers and software specialists, this medium-sized company is committed to next-generational R&D, bespoke project consultation, rigorous testing of prototypes and first-class manufacturing.

Under the expert guidance of Stefan Marx, the company is divided into two specialised sections: Ocean Power Products and Ocean Monitoring Equipment offering a range of products tailored for various marine and subsea applications.

The Ocean Power Products are supplied primarily to customers in offshore oil & gas companies, monitoring stations/moorings, subsea applications and autonomous underwater vehicle (AUV), remotely operated vehicle (ROV) manufacturers. The Li-Ion battery systems (PowerPacks) range from standard, subsea, vehicle, customised batteries, chargers to battery-management systems (BMS.) The advanced-precision titanium housing is fully customised and can be used for depths up to 6,000m.

The subsea batteries, for example allow high-performance for a design life of 25 years, with the electronic and Li-Ion cells meeting meticulous, optimised safety standards. The rechargeable Li-Ion batteries provide robust subsea Uninterruptible Power

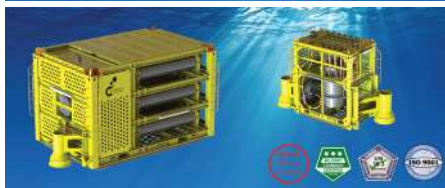

Supply (UPS) and are perfect for marine and offshore technology applications, offering next-level capacity.

"Our batteries undergo rigorous heat, shock and vibration testing, to reach the UN T38.3, MIL-STD, DNV or API17F standards of compliance and other on request," said Stefan.

The PowerPacks™ automatically protect itself e.g. at low voltage, to prevent damage, leaving operators assured of safety at all times, with the capacity to disconnect in the event of overcurrent or external short circuit. The advantage of Li-Ion batteries over Alkali primary batteries, is the high current operational features, ability to function at subzero temperatures and during high currents/peaks. Furthermore, the corrosion-free titanium housing can be used up to depths of 6,000m. The batteries are used for industrial applications and are tested in accordance to API17F, MIL-STD, DIN-EN and DNV – according to the application.

The ocean monitoring equipment provided by SubCtech is essential for scientific institutes, researchers aboard vessels, and sailors. This equipment facilitates comprehensive monitoring of surface and subsea

environments, focusing on greenhouse gas levels and micro-plastic sampling. The flagship product, the Autonomous Underway Measurement System (AUMS), is specifically designed for pCO₂ monitoring on 'Ships of Opportunity.' It is highly versatile and can be enhanced with additional sensors, such as the Meteo Top-Box for Sea-Air Exchange flux measurements and other third-party instruments.

The latest Microplastic Sampler for example, offers autonomous monitoring on any type of sea vessel and can detect even the smallest presence of microplastics in the water, down to particles per m³. The next-level robust, waterproof design provides accurate sampling, even on high-speed boats travelling at 30kn.

Stefan said, "We are experiencing rapid growth in our industry, driven by high demand for our Ocean Power products. We serve customers globally, including Europe, Asia, Australia, and the US, ensuring safe transport of our UN T38.3 certified Li-Ion batteries worldwide via airline cargo."

"Our professional sales partner network streamlines service delivery across regions. In response to exponential growth, we've nearly doubled our staff to 76 and plan to expand our facility from 1,200sqm to 4,000sqm."

"We prioritise environmental sustainability, using LED lighting, promoting public transport, and recycling all components, including batteries. Our Microplastic Sampler aids scientists in monitoring ocean microplastic pollution, which affects marine life and human health."

"Our latest innovation, the Subsea 2 MWh Energy Storage System has now successfully passed its final field-testing stage: the system has been commissioned and tested in situ and, therefore, has already reached the Technology Readiness Level 6 (TRL 6), according to API17Q, which exemplifies our commitment to high standards."

"Looking ahead, we aim to lead in Subsea and Ocean Power Solutions and Ocean Monitoring Systems globally. We seek strategic partners and are eager to expand our network within the international Oceanology sector."

For more information, please see the website below:
T +49 (0)431 220 39880
info@subctech.com
www.subctech.com

Ocean Power

Transform into the cost-efficient and sustainable future



Li-Ion PowerPack™ - Underwater power solutions

Highly reliable, efficient and safe Li-Ion batteries - Made for harsh offshore and subsea conditions!

Energy Storage Systems

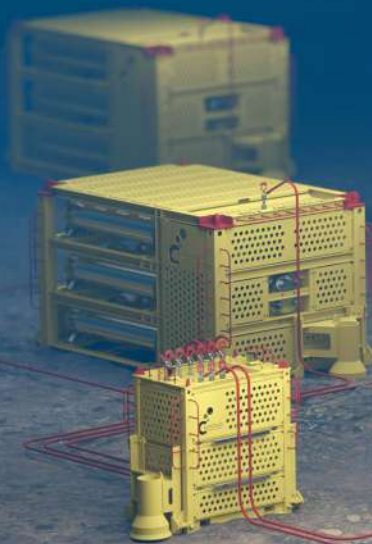

Vehicle Batteries



String Batteries



Subsea UPS



www.subctech.com



We Innovate Valves. We Build Valves. We Are Valves.

World-leading

Valves for Hydrogen, Carbon Capture,
Topside, Subsea, and Pipeline Applications.



olivervalves

Instrument & DBB Valves

- Manifolds, Needle, Check and DBB Valves to 22.5K psi
- Cryogenic
- Severe Service 650°C, 10K psi
- Forged & Bolted Construction



oliverhydcovalves

Hydrogen & Carbon Capture Valves

- Instrumentation, Ball, Needle and DBB Valves for Hydrogen and Carbon Capture Applications
- Pipeline Ball Valves upto 18"
- 10K Ball Valves for Hydrogen Fuelling Stations



olivertwinsafe

Pipeline Valves

- 1" to 20" Bore Size
- High Temperature
- High Pressure
- Cryogenic
- API 10K Design



olivervalvetek

Subsea Valves

- Diver & ROV Operated Needle Valves
- Ball Valves Upto 15K
- Manual & Hydraulic Parallel Slide Gate Valves 3/8", 1/2", 3/4" and 1"



We Manufacture Valves for Global Energy Projects.
To Find Your Local Supplier, **Contact Us Today.**



Reliability Under Pressure

+44 (0)1565 632 636 | sales@valves.co.uk | www.valves.co.uk
Oliver Valves Ltd Parkgate Industrial Estate, Knutsford, Cheshire, WA16 8DX, United Kingdom

olivervalves

CML readies itself for a surge of new market opportunities

CML Innovative Technologies (CML) is the leading manufacturer of LED signal lamps for all industrial applications and has been working with light since 1931. As a market leader in its field, CML was one of the first companies to introduce LED lamps and now has one of the broadest ranges of miniature lighting products in the world. "In 2004, the company became CML and continued to grow, establishing its international pedigree with two factories in Guangzhou, China, and Sibiu, Romania. While CML remains in Bury St Edmunds, the group was acquired by Spain's Grupo Antolin, which employs 28,000 people globally," stated Roger Neal, Commercial Manager.

From lamps for signalisation, panel mount indicators, LEDs, LED displays, medical lamps, and aviation lamps, CML provide light to an abundance of markets and pride itself on the ability to be as flexible and adaptable as possible in the manufacture of their own branded products to meet customer specifications and demand.

"CML in the UK focuses on specialist applications mainly manufacturing lighting solutions for automotive, aviation and general industries. We manufacture a standard range of products and customer-specific solutions from customer concept to production, including in-house design. Our portfolio runs to thousands of miniature lighting options in size, function, colour, finishes and voltages," said Roger.

CML is continually developing its own product range and has recently witnessed positive movements from customers seeking more product value. Some competitors fall short as they only provide a face value market product however, CML offers further manufacturing capabilities such as the add-on of cables and connectors to a product, which carries weighted value. The ability to meet customer specific requirements has attracted much attention in the industry as the manufacturing processes available from CML dramatically reduce production time through its made to order service.

"Nothing is impossible for us, we produce to customer demand working with customers. We have done work for individual airlines and collaborated



with their design division to manufacture LED replacements for incandescent lamps. There is a cockpit lamp, which we have produced for years, and there can be up to 1,200 different pieces per aircraft of that particular type. Our possibilities are endless," remarked Roger.

You will find CML products all over the world, from medical applications to gaming industries, by having full control of the entire value chain enables CML to be flexible with our clients' requirements. Since COVID-19, 50% of the business has come from industrial sectors. "Automotive sales have improved in the last year and the industrial side has witnessed significant growth. The pandemic has only made us stronger as a company, and as a result, our flexibility has generated an upturn in demand and helped create new business opportunities," said Roger.

For more information, please see below:
T 01284 714700
uksales@cml-it.com
www.cml-it.com/en







High Quality Panel Mount Indicators

CML IT continues to be the number one supplier of panel mount indicators, LED lamp replacements and LED tower lamp solutions. PMI highlights include:

- Plastic and metal bezels with a wide range of options in stock.
- Development of custom solutions.
- IP40 and IP67 ratings.
- UK manufacturing facilities.

Contact our Customer Services department to discuss your requirements today.







CML Innovative Technologies Ltd,
 69/70 Eastern Way, Bury St Edmunds,
 Suffolk, IP32 7AB, United Kingdom
 Tel: +44 (0)1284 714700
 email: uksales@cml-it.com

Visit our website at: www.cml-it.com

SEMOTA: Sense, monitor, trigger, act

The new remote monitoring solution from interface force

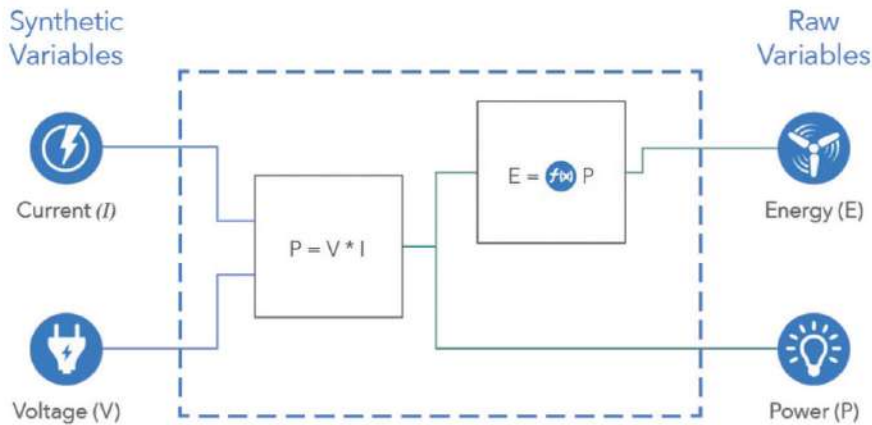

SEMOTA is a hardware and software solution with a web-based application that enables the remote monitoring of any load cell, force, torque or pressure sensor, using our Wi-Fi enabled hardware.

SEMOTA Continuous Remote Monitoring provides dynamic dashboard views of your events, analysis and device control. Information can be captured and stored for review and in depth analysis. Linkage to common messaging systems deliver live alerts for device management. Tailor and build applications to suit your needs and devices. Read

more below, then complete the form and we'll arrange a demonstration.

THREE YEARS STORAGE

Whether your data is needed every day or every few seconds, SEMOTA is optimised to receive, compute, and return millions of data points across the globe.

LIVE DASHBOARDS

Using SEMOTA point-and-click application development tools, create real-time dashboards to analyse data and control devices. Visualize

data with SEMOTA stock graphs, charts, tables, indicators, maps, metrics, and control widgets or develop your own using the HTML canvas and your own code. Share your data through public links, or by embedding dashboards into custom web applications.

EVENTS ENGINE

Add conditional and complex business logic to your hardware with triggered webhooks for M2M communication, and SMS, Email, Telegram, and Slack alerts to keep operators on-the-ball and informed.

SYNTHETIC VARIABLES

Transform raw data into insights with Synthetic Variables that compute complex math formulas and statistical expressions.

USER MANAGEMENT

With SEMOTA cloud software, you can build applications to best fit the operator's needs. SEMOTA administrators can configure permissions and restrictions to any end user or operator who interacts with dashboards, devices, and/or events. Need a user to be able to oversee multiple organisations? Not a problem. You can optionally add more users or organisations to your account and we can configure your users to best suit your application.

T +44 (0)1344 776666
info@interfaceforce.com
www.interfaceforce.com

The importance of Load Cells in Oil and Gas

The oil and gas industry relies heavily on load cells for safe and efficient operations. From offshore platforms to drilling equipment, they provide valuable data to improve operations, increase production, and ensure the safety of workers. Interface load cells are used in many facets of oil and gas, including to ensure safe lifting, enhance equipment integrity, provide accurate measurements in field operations, and even assist with optimal storage tank management.

Interface stands out by offering ruggedised, high-accuracy load cells specifically designed for the **oil and gas** sector's demanding environments. Interface helps the **energy market** with force measurement solutions specially developed for harsh conditions, with sensors that can withstand up to 30,000psi and 500 degrees Fahrenheit.

Interface Oil and Gas Applications

Load cell technology is used in various oil and gas applications, including:

Downhole and Vertical Drilling

- Dry Load Cell Replacements for Wet Load Cells
- Drill String Weight and Tension Monitoring
- Oil Recovery
- Wellbore Perforation Equipment
- Wireless Drilling Systems and Rig Management

Flow Management

- Monitoring Pipeline Tension
- Pipeline Stress Monitoring
- Mooring and Riser Systems

Wellhead and Production Operations

- Tank and Silo Weighing
- Cementing Tools
- Wireline Tools
- Crane and Lifting Equipment

- Mixing and Separation Systems
- Offshore Equipment

Crude Oil Barrel Weighing Solution

A weighing system is needed to measure mass amounts of crude oil. Interface's solution is to secure four **SSB Sealed Beam Load Cells** at the bottom of a metal platform. The load cells measure the force applied by the weight of the barrels of crude oil. All four SSBs are connected to a **JB104SS 4-Channel Stainless Steel Junction Box** which is connected to the **480 Bidirectional Weight Indicator** to display the accurate weight results.

Power Tong Measurement System

As with many oil and gas applications, the demand for digital or recorded traceability is ever-increasing. A force and torque measurement system is needed to ensure there is an appropriate amount of torque applied to a power tong during the tightening and loosening of shaft connections during the drilling process. Interface's **WMCFP Overload Protected Sealed Stainless Steel Miniature Load Cell with Female Threads** is attached to the hydraulic actuator that controls the clamping force of the tong on the drill string, thus increasing accuracy over hydraulic measurements. The **2,400 Standard Stainless Steel High Capacity Universal Load Cell** is attached to the hydraulic actuator that controls the bottom tong's clamping force on the drill string. Interface's force sensors accurately monitor the motor of the power tong's tightening mechanism, ensuring it tightens during operation at the right amount of force. It also successfully measured the force of the hydraulic actuator controlling the tong's clamping force.

Interface prioritises customisation to meet specific client requirements. This may involve incorporating client-specific mechanical details or defining products

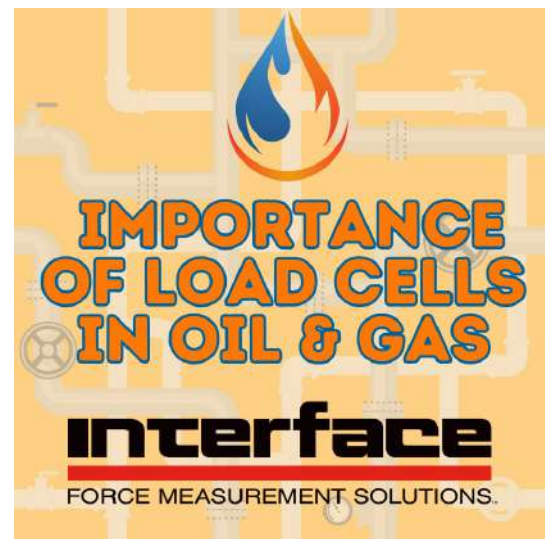

tailor-made for existing drilling systems and production equipment. An example of customisation is Interface's LowProfile™ series load cells, which helped an oil company improve recovery operations by providing accurate readings during an enhanced oil recovery (EOR) project. When oil is extracted from the ground, a refinement process removes sediments and other impurities. After the filtering process, the crude oil needs to be weighed before it can be redistributed.

See our Energy Industry: Force Measurement Solutions video here

<https://www.interfaceforce.com>

BUILDING UPDATE

ISSUE: 684 March | www.solutionspublishing.co.uk



Goland RECRUITMENT LTD

RECRUITMENT SPECIALISTS

- RETAIL
- CONSTRUCTION
- WAREHOUSE
- OFFICE

QUALITY DRIVEN RECRUITMENT
NEW CLIENT OFFERS AVAILABLE - CALL NOW

T: 01908 102078
info@goland.group www.goland.group

CHAS, Worksafe Compliance, SSIP, Constructionline, SAFER

Goland Recruitment

Here at Goland Recruitment Ltd, we have extensive network and experience in placing exceptional candidates for the role you require. Whether it be in Construction, Retail, Hospitality or Commercial we are at your disposal to do the leg work for you.



Save time and money when recruiting for temporary or permanent/full-time position as we spend a considerable amount of time reading through the specifications and searching for exceptional candidates.

Please give us a call or drop us an email today if you require our assistance and we will do our best to get you the right person for the job at a rate that suits your budget.

Our full time placements fees are normally 12% to 15% depending on the role and the salary, we now however have a set rate for all permanent roles placements of 8% no matter what the salary, but for your first two placements we are running a special offer of 5% across the board so don't miss out.

Please keep us in mind for all your Recruitment requirements, much appreciated.

Please see details below:
T 01908 102078
info@goland.group
www.goland.group
<https://www.facebook.com/2017goland>



Independent Access Sales
see them on.....III



Checkedsafe
see them on.....V-VII



Kedel
see them on.....IX



DCON Safety Consultants
see them on.....XII-XIII



Paramount Waste
see them on.....XVII



Gromtec europe Ltd.

Available from your electrical wholesaler

Simonbox IP66 Waterproof Floor Outlet

Occasional Power Outlet ideal for concourse, garage showrooms, pop up display areas

NEW DESIGN

Available in two finishes

For more information
www.simonbox.co.uk - 0203 2867949

SIMONBOX: Revolutionising electrical installations

The SIMONBOX IP66 exemplifies outstanding quality and innovation, setting a new standard in the industry by addressing the design challenge of making a waterproof floor outlet which is easy to access and easy to use.



Designed for use in hard floor areas which require occasional power, data connection, and an IP protection rating, the SIMONBOX IP66 plays a significant role in the advancement of electrical solutions.

For example, its ease of use is remarkable. There are no lids to unscrew or extra parts to assemble. Users simply pop open the lid using the standard slide or the Allen key security mechanism. Inside, the outlet can be fitted with either a UK 13amp or 5amp socket. When in use, the outlet meets the IP20 standard, and when closed, it achieves IP66 protection.

The NEW Simon-Box range is available in two finishes: Brushed stainless steel and Matt black steel. The floor box is also available in two sizes, single and twin and with data and USB charging options. Depending on the floor type, there are two back box options: one for screed floors and another for raised or suspended floors.

CE and UKCA certified, find SIMONBOX available via your local electrical wholesaler or online at: www.simonbox.co.uk

Get in touch for more information: info@gromtec.com.



**SUPPORT
for success**
Green Skills Training And Consultancy

Support for Success

Who we are:

Here at Support for Success, we shine brightly in the realm of sustainable construction. We are pioneers in Green Skills Training and Consultancy.

quality and effectiveness of our programs, offering participants the opportunity for industry-standard certification and recognition.

How to take our courses:

All our courses can be delivered on your premises or at one of our local venues. Please get in touch with us, to see what will suit you best.

Learn from our experts:

Here at Support for Success Ltd, we aren't just another training company; we're specialists in retrofit training and support, all delivered by experienced and qualified trainers. We're passionate about training the existing workforce and awarding them with a recognised qualification, our courses are also a valuable tool for individual homeowners.

Did you know that it is mandatory to have annual inspections on your External Wall Insulation?

Our Inspection Maintenance and Repair course awards participants with a Level 3 Certificate in Competence issued by the awarding body, The NOCN. This course prevents any issues with the invalidation of warranties and guarantees through unchecked defects. This course is also CPD accredited.



PART OF NOCN GROUP
APPROVED CENTRE

The UK's growing emphasis on retrofitting homes presents a critical need. We address this need by educating and upskilling both the current workforce and the next generation to come.

We have developed these courses in collaboration with industry experts and esteemed entities – such as, the National Insulation Association, the Insulated Render and Cladding Association, the Solid Wall Insulation Guarantee Agency, Exeter College, and SWIFIX Ltd. This collaborative approach ensures the credibility and relevance of our offerings, making us leaders in the field.

“Building a sustainable future – our dedication to green skills training equips you with the tools to thrive in this ever-evolving industry.”

T 01884 211542
info@supportforsuccess.org
www.supportforsuccess.org

In a world facing critical environmental challenges, our initiatives are not only commendable, but they are necessary for a healthy future. Our core mission is to provide meticulously crafted training courses that are both practical and theoretical. These courses range between one to three days and include assessments along with multiple choice exams.

Our courses:

- Inspection Maintenance and Repair of External Wall Insulation
- Understanding Domestic Retrofit
- Floor Insulation
- Draft Proofing
- Loft Insulation
- Internal Wall Insulation
- External Wall Insulation

Accreditation from NOCN and endorsements from key industry bodies further validate the



Support for Success

Building a Sustainable Future: Support for Success in Green Skills Training



**SUPPORT
for success**

Did You Know It Is Mandatory To Have Annual Inspections On Your External Wall Insulation?

Get In Touch:

01884 211542
INFO@SUPPORTFORSUCCESS.ORG
WWW.SUPPORTFORSUCCESS.ORG



IAS: Success at APF 2024 and exclusive new Socage product

Independent Access Sales (IAS) sell market-leading manufactured platforms, such as Easylift Spider Platforms, SOCAGE Truck Mounting Platforms.

Based in Huntingdon, IAS has gone from a relative newcomer on the market to selling million-marked machines over the last two years. One of the main reasons for the company's success is the focus on solid customer service. Founder Richard Martin has 35 years' previous sector experience across scaffolding, supervisory roles and surveying and understands the industry inside out.

With a focus on brand awareness, IAS brought its Easylift Spider Platforms and SOCAGE truck-mounted platforms to the APF Show from the 19th-21st September at Ragley Estate, Warwickshire. APF has been running since 1976 and is a respected dedicated biannual event for the whole forestry, woodland, arboriculture, firewood, fencing, tree and



timber sectors. It's the largest of its kind and attracted 23,000 visitors this year.

The Easylift Spider Platforms are also ideal for tree surgeons: with the range available from 13M up to 53M. The Easylift platforms give the owner operator assurance and flexibility in business: simply put – more

control over what to do in different environments. For tree surgeons, this allows operators the advantage of closing the Easylift Spider Platform down to less than 1M working width to take down a narrow footpath in a forest, to setting up on a hill to work at great height.

For more information or to speak to Richard Martin directly, please see the details below:
M 07483 246878
enquiries@iasales.co.uk
www.iasales.co.uk

Bluerun Ltd once again achieves excellence in the workplace

Upon reopening its doors in May 2020 after the COVID-19 pandemic, Bluerun Ltd has gone from strength to strength with its trusted brand now being known as one of the best in the joinery industry that has recently attracted big name brands turned clients, Starbucks and Waitrose.



Since 2022, the company has continued to strengthen in terms of revenue and new business. It has managed to maintain a strong conversion rate despite the current economic crisis and has found that enquiries for larger jobs as opposed to 'single window' types of jobs has been more popular especially from domestic clients.

Based in Wimbish, near Saffron Walden in Essex, Bluerun manufactures quality, bespoke joinery items for the commercial market from door and window packers to shopfronts, reception desks, mainframes, pub doors, and years ago, even made a trebuchet for Stansted Mountfitchet castle!

Of course, the company has the capabilities to manufacture most things from timber, hardwood, softwood, panels and sheet material. Some common items Bluerun Ltd manufacture for the domestic building market include windows, doors (exterior and interior), bi-folding doors, staircases, bespoke storage units and wardrobes, all of which

come with the option of being sprayed in primer or to a finish.

If you're looking for items made from both hard and softwood or even veneered and painted panels, Bluerun can reproduce an array of items including replacement sashes, where it can manufacture a brand new one on a like for like basis, so the mouldings will match.

Contact
T 01799 599995
dee@bluerunltd.co.uk
www.bluerunltd.co.uk

Elite event crewing services

Olympus Crew offers a comprehensive range of event crewing services, distinguished by its highly trained and versatile team. With expertise spanning from tools and staging to AV and lighting, the crew is prepared to handle a range of diverse tasks efficiently.

Founded in 2018, Olympus Crew has rapidly established itself as a versatile and reliable partner in the event industry. Over the past six years, they have successfully managed a wide array of events, including festivals, corporate gatherings, live shows, and sporting events. With seasoned crew chiefs at the helm, Olympus Crew ensures smooth operations, effective client communication, and proficient management of large on-site teams. Its dedication to excellence makes them a standout choice for event execution.

Olympus Crew have the ability to travel all over the

UK and even overseas when required. The team is made up of diverse skillsets including carpentry, audio visual, physical and mental strength, as well as forklift and IPAF operators.

The crew will be with you from the start to the end of each project. Whether that be picking items from a warehouse, building and painting sets in a workshop or loading and unloading trucks, Olympus Crew offer as much off-site as they do on.

If you're looking for an elite crew that is professional in its execution with a hardworking attitude, get in touch today and a member of the team will be in touch within 48 hours.

M 07904 903452
info@olympuscrew.co.uk
www.olympuscrew.co.uk

Quality bespoke steel buildings and structures



Doncaster-based Castle Steel Buildings Limited is the UK's number one supplier of cold formed steel buildings. From storage, workshops, private garages, agricultural buildings to commercial buildings, the Yorkshire company can design and supply for any applications.

Castle Steel Buildings work across commercial, industrial, leisure, equestrian and agricultural sectors to create the very best design solutions that last decades with little environmental impact.

Steel buildings are revered for robustness, flexibility and sustainability properties and can be moulded into many different shapes and sizes, making this the design product of choice for bespoke versatility. Steel is often chosen over wood in the industry as a material as it doesn't rot, warp or deteriorate with variables such as moisture or pests, allowing for structural longevity. Galvanisation and special paints also offer extra protection against corrosion and rust.

The team at Castle Steel Buildings can customise a building to suit your specific design purposes, from small storage sheds, to large commercial buildings. The designs can include the following options: insulated or non-insulated, roller shutter doors, personnel doors and many other features.

To find out more contact Castle Steel Buildings Limited on: 01302 301402 or visit the website for a free, no obligation quote at: www.castlesteelbuildings.co.uk

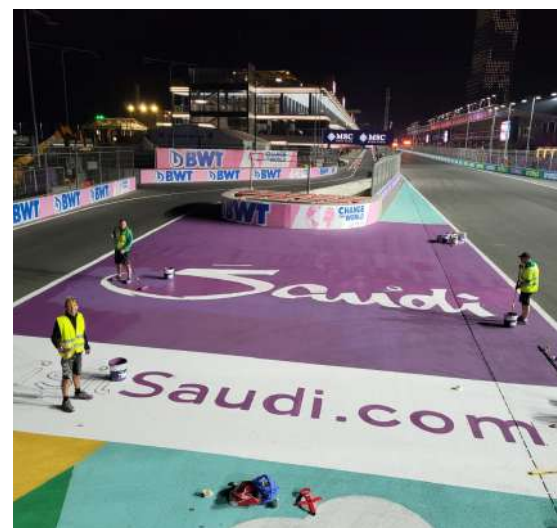

ACCESS ANY- WHERE

IA INDEPENDENT
ACCESS SALES

CONSULTANCY

Independent Access Sales will find your perfect access platform. With 35 years of experience in the access industry we will find the platform most suited for your needs and supply at the best price achievable. We will also manage the servicing of the supplied platform through our contract servicing department.



SERVICING

We are a complete service management facility throughout the UK. We will advise you when your platform requires its six month Inspections arrange the works and supply the required certification, all at your premises, We have access to a large network of access platform components and therefore any additional repairs can be undertaken.



**GET IN TOUCH TODAY OR VISIT
OUR WEBSITE TO VIEW OUR RANGE.**

T. 07483 246878

E. ENQUIRIES@IASALES.CO.UK

W. WWW.IASALES.CO.UK



Celebrating 10 years of Checkedsafe

Multi-Award-Winning Checkedsafe offers a complete digital cloud solutions package to fleet management across commercial fleet transport, public and private transport, emergency services and plant-hire vehicles. This effectively allows companies to monitor vehicle compliance across every vehicle in the UK and even while abroad. It costs as little as £1 per vehicle per week for a cost-effective paperless reporting system.

These multiple award-winning solutions have entirely digitised vehicle compliance, significantly streamlining the daily operations of both fleet drivers and management. Bus, HGV, Van, Car, Grey Fleet, Plant & Machinery (any commercial vehicle) drivers can download a handy app onto their mobile devices to use tailor-made vehicle checklists. The app even functions whilst in remote areas with no phone signals to enable checks to be completed on the move. This flexible, handy app is so easy to use: just check and go! The main office then receives each report allowing for a complete audit trail across the company. This seamless system makes sure that vehicles are Driver and Vehicle Standards (DVSA) compliant and automatically generates scheduling slots for vehicle ad-hoc repair as well as routine MOTs and servicing.

We caught up with Director & Co-Founder, Gary Hawthorne, to find out how Checkedsafe has fared over 2024, "We expanded our portfolio of compliance tools to include Driver Licencing Checks and GB Domestic Hours modules – these have all been successfully completed and launched. We are delighted to say that the GB Domestic Hours App is a market-first in the UK and was the result of intensive R&D. We created the algorithm around a complex set of rules that are currently managed by paper systems only.

"Checkedsafe is a compliance tech company co-created by Darran Harris and myself ten years ago. Darran has over 20 years' industry expertise as a Litigation Solicitor, specialising in road traffic issues and has worked as a solicitor with major logistics companies, successfully representing them at Public Enquiries. I have over 30 years as a Transport Professional, from, initially Driver, Manager, TFGM (was GMPTE), Central Government Owner/Operator and as a DVSA Accredited Earned Recognition Auditor.

OVER

10



of compliance excellence

"Our unique joint partnership has thrived in the commercial fleet community, as we know our product inside out and why it's required. We are happy to collaborate with other 'professional companies' and prefer to do so, rather than try to compete with established solutions. In fact, new tech collaboration with APIs is much easier now, so bringing together expert areas is a far better model than trying to split the atom alone."

Commercial fleet compliance has historically remained heavily paper-based but the trend is now moving towards technology, especially with increased Grey Fleet ownership. Checkedsafe are the go-to experts in this domain and support private employees and whole fleets manage compliance, as Gary continues, "Moving people from paper to technology ensures huge savings in time, paper and storage – all of which impact the environment. You can now effectively manage a 100-strong vehicle fleet from your mobile phone, if you so wish (though a laptop is advisable, with secure back-office options). Therefore, there really is no need to store copious boxes of reports plus everything is received in 'Realtime' so any defects/issues can be resolved quickly. This reduces

overall long-term costs and downtime as better repair planning can be achieved."

"We are professionals in our respective industry not salespeople or tech people. We both have a passion for compliance facilitating change for the better. As an ex-Operator, I fully understand the issues at hand and as an Accredited Auditor, I know the challenges companies face daily. This has allowed us through Checkedsafe to develop our product base from an expert knowledge base. After designing our ideas on paper, we hand it over to our Tech Wizards to digitise those concepts. This 'old school' format allows us to really thrash out the ideas on paper first before committing to the tech stage."

Looking ahead to next year and beyond, Checkedsafe is focused on building further on this year's product line by tweaking existing products, providing add-ons to new products and back links to other areas of the platform. With growing client demand, Checkedsafe is looking forward to future collaborations.

"We have a very exciting project for early 2025 but are keeping tight-lipped for now. It will be a very exciting addition to our existing product portfolio. We take great pride in our customer-centric focus: developing off the basis of customer feedback. All requests are evaluated and then we develop and launch that feature for the whole Checkedsafe client base. We do not charge for this as we believe in sharing good practice and one idea may actually benefit many others."

To find out more about Checkedsafe or to access the 30 day free trial, please visit the website below:
T 01282 908429
info@checkedsafe.com
www.checkedsafe.com



How are YOU prioritising the safety of your commercial fleet?

Let's face it – how confident are you that your commercial drivers are truly prioritising safety on the roads? Can you be certain that daily walk-around checks are performed accurately? How do you know your drivers are actually getting out of their cabs to inspect their windcreens and tyres before ticking every box and going on their way? For many commercial fleets, the truth is that you don't.

It is well-documented that driving for work is one of the most dangerous things you can ask your employees to do. A staggering 33% of road deaths and 20% of serious injuries involve someone driving for work. So what are you doing about it?

The reality of road safety in commercial fleets

Managing a fleet of commercial vehicles is no easy task. The logistical challenges are immense, and ensuring the safety of each driver is paramount. However, safety protocols can often become mere checkboxes in a long list of daily duties. When the pressure is on to meet delivery schedules and performance targets, it's easy for thorough inspections to fall by the wayside.

But this isn't just about meeting regulatory requirements or avoiding fines. The human cost is significant. When a driver skips a safety check, it could lead to severe consequences – an accident that could have been

prevented, injuries, or even fatalities. These incidents not only affect the driver and their family but can also have a profound impact on your business, from increased insurance premiums to the potential loss of contracts.

The importance of thorough walk-around checks

Daily walk-around checks are a crucial part of ensuring vehicle safety. These inspections are designed to catch potential issues before they become serious problems. A cracked windscreen might seem like a minor issue, but it can obstruct the driver's view and become a major hazard. Worn tyres can lead to blowouts, especially at high speeds, putting the driver and others on the road at risk.

Ensuring that these checks are carried out properly is vital. This means making sure that your drivers are not just ticking boxes but are actually getting out of their cabs and performing the inspections thoroughly. However, manual checks can be inconsistent. Fatigue, complacency, or simple oversight can lead to missed steps, and without a robust system in place, these errors can go unnoticed until it's too late.

Choosing CheckedSafe for safer roads

This is where CheckedSafe comes in. CheckedSafe is a comprehensive SaaS solution designed to ensure that your fleet's safety checks are carried out accurately and efficiently. With our system, you can digitise your inspection processes, making it easier for drivers to complete checks and for you to monitor compliance.

We provide a user-friendly app that guides drivers through each step of the inspection process, making sure that no item is overlooked. We do this by dating, timestamping and geolocating every time they press a button, so you can see if they have raced through the checks in two minutes or carried it out properly. The software also uses an accelerometer to make sure they're walking around the vehicle to do the checks, not just sitting in their cab.

Meanwhile, from your offices, you'll be able to monitor user activity, view comprehensive maintenance



reports in real-time, identify outstanding tasks and vehicle defects, and schedule services with our intuitive system. We also offer secure data storage and a clear end-to-end audit trail, so that you can protect your business in the event of investigations.

Don't just tick boxes, commit to comprehensive safety

Don't wait for a serious incident to highlight the gaps in your safety protocols. Act proactively to mitigate risks and ensure that every journey your drivers make is a safe one. With CheckedSafe, you gain peace of mind knowing that your fleet is compliant, your drivers are protected, and your business is safeguarded against avoidable accidents and their associated costs. Prioritise safety, protect your drivers, and ensure the longevity of your business with CheckedSafe.

Take the first step towards a safer fleet today by visiting our website at: www.checkedsafe.com or ring us on: 01282 908429.



Simple and inexpensive compliance solutions tailored to any industry.

CheckedSafe provide compliance services across commercial & plant hire businesses, utilities companies, and many other service sectors that are monitored for compliance.

Vehicle Compliance

The vehicle compliance system for all fleets with paperless defect reporting and office portal.

- ✓ Driver's app
- ✓ GPS tags
- ✓ Back-office portal
- ✓ DVSA compliant

Licence Checks Service

Conduct licence checks remotely ensuring your drivers have the correct credentials.

- ✓ Simple to use
- ✓ Pay as you go
- ✓ Remote use
- ✓ OCR technology

GB Domestic Hours

Demonstrate your GB domestic hours compliance whenever needed.

- ✓ Ensure legal compliance
- ✓ Manager driver fatigue
- ✓ Improve productivity
- ✓ Real-time alerts

Lone Worker

The smart way to protect lone workers with visibility of all your team members in the hub.

- ✓ SOS red alerts
- ✓ Welfare checks
- ✓ Worker down alerts
- ✓ Group notifications

Dynamic Risk Assessment

Identify hazards, assess risk, take action, and review reports, on-site, and in real-time.

- ✓ Simple to use
- ✓ Pay-as-you-go
- ✓ Remote use enables
- ✓ OCR technology

Try free for 30 days
Visit checkedsafe.com



One-stop-shop for indoor and outdoor sports and leisure spaces

The UK has seen an explosion in indoor recreational spaces, from trampoline parks, Ninja Warrior courses to soft play centres.

The first indoor Trampoline Parks opened in 2014 and over the last ten years, over 150 parks have opened. From corporate days out, to children's parties and clubs, trampoline parks are a growing industry.

Ninja Warrior Courses have likewise sprung up in major cities across the country, all inspired by the ITV hit programme Ninja Warrior UK. From Leicester to Liverpool, children and teenagers of all ages put their Ninja skills to the test in a series of physical obstacle courses.

Soft Play Centres hardly need an introduction, as most aunts, grandparents, and parents will have taken their child or younger relative to one at some point. Come rain or shine, all year round, soft play centres provide hours of safe, sociable fun for babies,



toddlers and children. Designed for children to let off steam, the integrated slides, ball pits and play areas are perfect for weekly meet ups and children's parties.

For companies looking to increase franchises and open new centres, it's always good to use manufacturers renowned for professionalism, expertise and excellent customer service. The Playcraft Group fits the bill with 40 years' children's play industry and 25 years' play centre attraction industry experience. Based in South Wales, the company offers a one-stop-shop for design, manufacturing, installing and maintaining trampoline parks, climbing walls, Ninja Warrior courses, adventure playgrounds and much more.

"We offer bespoke installations across the indoor and outdoor sports and leisure sector, as one of the few one-stop-shops in the industry. Our previous high-profile clients have included Disney, Land Rover and Cartoon Network and we work with farm parks, theme and holiday parks, schools, the FEC sector and more. We know the business inside out and we're happy to offer free 360° advice from business plans and models, to planning application support, insurance to franchising advice. From Jungle or Space themed soft play, climbing wall in a new upcoming urban space, to an exciting Ninja Warrior Course, we can do it all.

Currently we are working on a wheelchair-friendly, soft play section for a local soft play centre. We are adapting our soft play materials to incorporate the width of an electric or manual wheelchair. The end result will be an inclusive space for children in



wheelchairs. More and more soft play centres are adding sensory spaces (lights, textures etc) to support neurodiverse children, to increase inclusivity for children and their families," explains Mike Broadfield: founder, coach and consultant.

To start your indoor leisure franchise journey today, contact Mike on the details below:
T +44 (0)1792 422818
hello@playcraftgroup.com
https://softplay-manufacturer.com



CHOOSE US FOR 'DIRECT' SUPPLIES

Multiple Facilities

- Trampoline Parks
- Soft Play Areas
- Climbing Walls
- Ninja Warrior Courses
- Adventure Playgrounds

All In-House

One of the only companies who:

- Design
- Manufacture
- Install
- Finance

FREE 360° ADVICE

We help ensure your success with:

- Business Plan & Model
- Planning Application
- Success
- Financials & Insurances
- Franchising

Find out more at softplay-manufacturer.com
Tel +44 (0)1792 422818 | hello@playcraftgroup.com



Pioneering sustainability with Recycled Plastic Innovations

In this issue of Building Update, we are proud to spotlight Kedel as our top recommendation for eco-friendly plastic products in 2025.

This recommendation comes off the back of a fantastic year for Kedel. 2024 saw the company win double awards in the Feefo Trusted Service Awards 2024 as well as receive the Exceptional Service and Gold Trusted Service Awards 2024. These awards epitomise their exceptional customer experience across the board, which has been at the heart of Kedel operations since inception.

Kedel is a market-leading manufacturer and distributor of recycled plastic products, outdoor and park furniture. With a focus on sustainability, Kedel has been a front-runner in the industry since winning the 'Best Recycled Plastic Product' at the National Recycling Awards back in 2015.

Over the years, the family business has expanded, with a product range now serving a wide customer

base including local Government, housing associations, education, construction and domestic sectors.

The three founders are brothers: Kieran, Dermot and Lewis Walch, whose endeavour to bring sustainable products to the foreground have made Kedel products the 'industry's products of choice.'

"We manufacture plastic wood made from waste polystyrene, and we are also suppliers of many other types of recycled plastic profiles from other manufacturers. We stock tongue and groove boards, plastic sheet materials, decking, cladding, ground reinforcement and drainage grids, fencing and gates. In addition, we make a wide range of outdoor furniture often combining different types of recycled plastic into one product. These products include benches, tables, picnic tables, and notice boards just to name just a few. We also offer design services and have a large flatbed CNC (computer numerical controlled) machine for cutting and shaping to the CAD design parameters supplied by our customers,



or created for them by our in-house design team," explained Lewis.

Using recycled plastic offers a dual advantage: it significantly reduces the carbon footprint while delivering substantial returns for businesses. These products are rot-proof and require no ownership costs, maintenance, labour, materials, or replacement expenses, making them a cost-effective and sustainable choice.

Take Kedel's plastic fencing panels for example, which are an ideal solution for end customers, including housing associations. Unlike traditional wooden panels, they eliminate the need for frequent replacements. The entire sustainable range withstands frost without cracking and remains intact even under heavy rain, avoiding splintering or damage. Additionally, Kedel's benches and picnic tables are perfect for educational institutions, providing durable outdoor furniture without the burden of high maintenance costs.

To find out more about the full product range, click here: www.kedel.co.uk



The Zero Maintenance Alternative to Wood

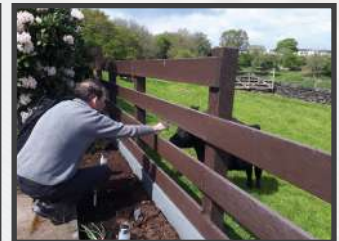

Recycled Plastic

- 100% recycled and recyclable
- Impervious to fungi, algae, insects
- Never rots, splinters or cracks
- Graffiti resistant
- UV Protected
- Eco-friendly and low carbon
- 100% maintenance free
- Lasts a lifetime



Please contact us on 01282 861325
sales@kedel.co.uk | www.kedel.co.uk



Quality and service count: Customised doors and panelling

Pandor is a leading manufacturer of customised doors and panelling across the UK to sectors such as commercial buildings, offices, hospitals and flats.

Established in 2014 by Mike Hill, the company has grown exponentially over the last nine years, priding itself on supplying exceptional customer service and high-spec products. Mike has expertise in the industry having worked in the fire door industry for over 40 years and along with his team is happy to provide customers with bespoke orders.

Pandor has production facilities in Sittingbourne, Kent and offices in London. We chatted with founder and director, Mike to find out more about the company, "We specialise in made-to-order client requirements for fire doors, decorative doors, frames and other associated items such as screens and windows."

"Our speciality though due to my background, is certified fire doors and door sets and we pride ourselves on a personal and prompt service with quick lead times on manufacturing."

"The COVID-19 pandemic set us back of course, as the construction industry ground to a standstill. We soon restarted though and have been ever busy, focusing on adding new services in the near future. Our unique selling point is our investment in modern machinery across the board, ensuring that we always produce the highest-quality products. These include a Holzher 5 Axis CNC Twin Bed Router,



heavy-duty sanding machine, veneer flow line press and first-class lipping and edge banding."

Fire doors are integral to optimised passive fire protection systems across industrial, commercial and domestic buildings in the UK. Precision-designed primarily to mitigate against the spread of fire, smoke and toxic gases from one area to another, fire doors allow occupants, whether residents or workers extra time to evacuate accordingly. A secondary factor is that compliant fire doors give firefighters more time to arrive at the scene of the fire and control the fire, before it spreads further. Using a system of compartmentalisation, with fire doors lined throughout in corridors or stairwells, can create fire-resistant barriers in a high-rise block and importantly help slow down the spread of fire and smoke.

Fire doors are given FD ratings from 30, 60, 90 to 120, with FD30 being the most common choice. This

typically gives 30 minutes fire safety protection, in the event of a fire.

Following the tragedy at Grenfell Tower, North Kensington where sadly 72 residents died, the subsequent Fire Safety (England) Regulations in 2022 came into effect on 23rd January 2023. With all eyes on optimised fire safety, Pandor can manufacture customised fire doors, in accordance with FD30, 60, 90 or 120 certifications.

"Our fire doors can be laminated, painted or decoratively veneered and our acoustic doors can also be fire rated. The acoustic door ratings are certified based on how well the sound is contained in the door itself. The doors are tested to different decibel (dB) levels, dependant on the end location, with the higher the acoustic rating, namely the louder the sound it can contain. For example, the acoustic rating for doors in residential flats is 29dB, raising to 30dB in a typical school classroom."

"We supply fire-rated panelling if required, in stock and cut sizes, with a choice of veneer, laminate or paint finishes. Finally, our door frames are manufactured to customised order, with clear or paint finishes," added Mike.

For more information, please see the details below:
T 0208 2797611
M 07909 530007
mike@pandor.ltd
<http://pandor.ltd>



Pandor BESPOKE DOOR AND PANEL MANUFACTURERS

FIRE DOORS | ACOUSTIC DOORS | PANELLING | DOOR FRAMES

THREE KEY VALUES

SUPERLATIVE QUALITY | SHORTEST DELIVERY | ATTENTION TO DETAIL

OFFERING SERVICE LIKE NO OTHER

EXCELLING IN ACHIEVING FAST LEAD TIMES
FOR BESPOKE FIRE DOOR SETS

QUALITY AND SERVICE WITH A SMILE

PROUD MEMBERS OF THE BM TRADA Q-MARK SCHEME
FOR FIRE DOORS YOU CAN DEPEND ON

UNIT F2/F3 | LONDON ROAD TRADING ESTATE
SITTINGBOURNE | KENT | ME10 1SX

CALL: 0208 279 7611 | 07909 530 007

EMAIL: MIKE@PANDOR.LTD | PANDORLTD@HOTMAIL.COM



QUALITY, CUSTOM MADE JOINERY



Bluerun Ltd have been manufacturing top quality, purpose made joinery for the domestic and commercial markets for over 30 years.

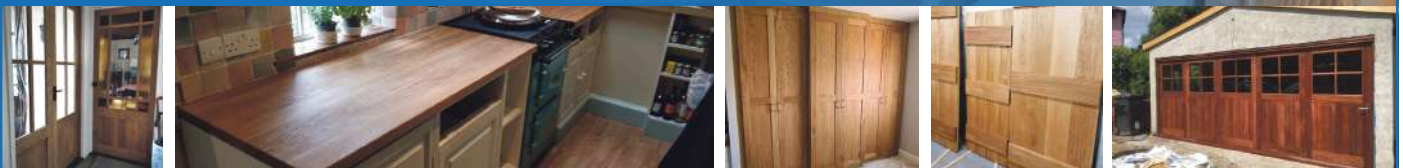

Please visit our website: www.bluerunltd.co.uk

Tel: **01799 599995** | Email: dee@bluerunltd.co.uk f [bluerunltd](#) @ [bluerun_joinery](#)

Water Monitoring & Treatment

efendi architectural

FILM | PHOTOGRAPHY | GRAPHIC DESIGN

www.efendiarchitectural.com | +44 (0) 7587054663 | info@efendiarchitectural.com

CONSTRUCTION | INDUSTRIAL | RESIDENTIAL | HOTEL



Make your project possible

DCON Safety Consultants Limited offers leading health and safety consultancy and construction statute advice services. The company prioritises and specialises in the highest levels of informed and intelligent advice, senior project resource allocation and compliance assurance. Informed by industry expertise, DCON Safety Consultants Limited knows that every project has potential risks, no matter what its potential benefits, so its team of highly experienced construction professionals helps to ensure clients' statutory conformity.

Upon gaining understanding of the specific needs, goals and desires of each client and their project, DCON Safety Consultants Limited is dedicated to implementing a design and construction management plan that will meet or exceed these requirements. And, DCON Safety Consultants Limited ensures that there is honesty, integrity, trust and professionalism underpinning every project.

Moreover, the company's services are centred on three delivery principles:

- **Maximising Quality:** The company implements proven health, safety and wellbeing strategies to help clients achieve high quality and cost-effective work commensurate with the design of their projects.
- **Minimising Risk:** The company effectively manages design and delivery risk on projects to match each client's desired risk level profile.
- **Managing Compliance:** The company relies on its extensive background working on a wide variety of projects to assist clients in developing, monitoring and maintaining compliance performance.

This excellent service would not be possible without the leadership of Diarmuid Condon, a construction industry leader who brings unique perspectives to encourage, support and mentor the abilities of his colleagues. As a construction professional with a surveying background and experience spanning two decades, Diarmuid is emblematic of DCON Safety Consultants Limited's commitment to providing outstanding services to clients.

Diarmuid has contributed his invaluable expertise to over 400 projects over 20 years, with a client list including public sector departments, corporate owners, real estate developers, main contractors, design professionals and infrastructural bodies. With this incredible portfolio, Diarmuid is helping DCON Safety Consultants Limited to become a leader in health and safety consultancy across the construction industry.

Key to DCON Safety Consultants Limited's services is working as a Project Supervisor for the Design Process and CDM Advisor in various



sectors across the Irish construction market. No project is too simple or too complex for the company's construction safety consultants, all of whom are construction professionals with an average of 20 years' experience in the built environment. The ability to maximise this knowledge and skillset means DCON Safety Consultants Limited can generate distinctive and innovative ideas from traditional PSDP service inputs and outputs.

DCON Safety Consultants Limited also provides its main contractor clients with intelligent, practical, and reasonable physical site safety advice to support compliance and good practice adherence. Behavioural safety outcomes inform how the company approaches each solution with the contractor and their supply chain, identifying opportunities for improvement.

To complement this, DCON Safety Consultants Limited can also help with clients' health and safety strategy. Its holistic and integrated approach can help unlock substantial benefits for clients by providing a structured, objective and SMART framework for full optimisation through the

creation of an environment that embraces health, safety and wellbeing.

This means DCON Safety Consultants Limited helps clients to improve their health, safety and environmental performance; enhance staff satisfaction thanks to improved performance; improve risk management and corporate governance with a clear audit trail; gain confidence from long-term planning, better sustainability and performance; and improve overall corporate reputation, including greater staff satisfaction and a more efficient procurement and supply chain.

If you are interested in finding out more information on DCON Safety Consultants Limited's full range of excellent services, head to the website or get in touch directly using the contact details below.

T +353 (0)1 611 1556
diarmuid.condon@dconsafety.com
www.dconsafety.com



Leaders in Built Environmental Safety and Health and Wellbeing Consultancy



Consulting on various aspects of project design, constructability and operational lifecycle matters for local and global commercial clients.

DCON Safety Consultants is committed to understanding the specific needs, goals, and desires of each individual client and project. Upon gaining this special understanding, we commit ourselves to the implementation of a design and construction management plan that will meet or exceed these requirements. Our foundation for each project is honesty, integrity, trust, and professionalism.



OUR SERVICES

- DESIGN SUPERVISOR
- PLANNING COMPLIANCE
- CONSTRUCTION HEALTH & SAFETY
- HEALTH & SAFETY STRATEGY
- EXPERT WITNESS

Please visit: www.dconsafety.com

Email info@dconsafety.com • Phone +353 (0)1 611 1556

DCON Safety Consultants, Suite 5, Fitzwilliam Square East, Dublin 2

Warwick Buildings

Adding a high-class timber building to your garden or business premises can hugely enhance both the usefulness and the value of your property, not to mention providing a cosy hideaway, quiet workspace, playroom or artist's studio. These versatile structures can be installed at far less cost than an actual house extension and, in most cases, don't even require planning permission.

Warwick Buildings is your go-to company for excellence in quality timber structures from

garden rooms to office pods, bespoke for your own wishes and ambitions.

Formed in 1988, Warwick Buildings has a proud history of manufacturing timber buildings for private and commercial use. The company has its own premises and in-house team for designing, making and installing the structures, complete with the insulation, glazing and services to make them thoroughly weathertight, cosy and comfortable all year round.



or book an appointment at their showroom now to discuss your needs. Warwick Buildings, Nightingale Lane, Southam Road, Long Itchington, Southam, Warwickshire CV47 9AT.

T 01926 815757
warwickbuildings@outlook.com
www.warwickbuildings.co.uk



Garden rooms are the new 'must have' for the modern garden, often with bi-fold doors, cedar cladding and curved roofs for added contemporary appeal.

Warwick Buildings also make garden offices to suit all the many people now working from home, as well as timber garages, upmarket sheds, studios, therapy rooms and commercial spaces such as timber shop spaces.

Find your inspiration at: www.warwickbuildings.co.uk



TIMBER GARDEN BUILDINGS



**GARDEN OFFICES
TIMBER GARAGES
WORKROOMS**



WARWICK BUILDINGS

**NIGHTINGALE LANE
LONG ITCHINGTON
SOUTHAM
CV47 9AT
01926 815757**

'Quality Timber Buildings For All Your Needs'

www.warwickbuildings.co.uk



STEEL BUILDING SOLUTIONS

+ SINGLE SKIN + COMPOSITE + ROLLER DOORS + WINDOWS +



INDUSTRIAL



AGRICULTURAL



DOMESTIC

+ SKYLIGHTS + PERSONNEL DOORS + INSTALLATION OPTIONS +

GET A FREE ON-LINE QUOTE AT

WWW.CASTLESTEELBUILDINGS.CO.UK

OR CONTACT US ON

01302 301402

INFO@CASTLESTEELBUILDINGS.CO.UK

Building Trade Products

NORDIC PANELS – PERFECT INTERIOR WALLS & CEILINGS

Produced from pure wood fibre with only water, heat and pressure

Ideal for any project, from renovations to new builds

Suitable for all rooms, including bathrooms and kitchens

Easy to install and ready painted with water based acrylic paint



Pre-painted Nordic Panels for walls and ceilings give an outstanding, durable finish in any room without the need of skimming, priming or painting, saving on time and labour cost. Nordic Panels can be applied directly onto stud work or over existing surfaces to provide high quality walls and ceilings. Sustainable and without harmful solvents, Nordic Panels have a fantastic M1 rating for indoor emissions, making them one of the cleanest interior wood fibre panels on the market.

If you want a professional interior that is easy to install, durable and environmentally friendly, then Nordic Panels are for you!

Visit: www.scandinaviantrading.co.uk

Please call: 01932 645050

REQUEST A QUOTE





Fennell, Green & Bates

MINING ENGINEERS, SURVEYORS & ENVIRONMENTAL CONSULTANTS

Fennell Green & Bates Chartered Surveyors is a 150 years old practice based in Wakefield. At FGB, we specialise in building condition surveys, house structural surveys, project management, town & country planning, coal mining risk assessments, site investigation and remediation of brownfield land.

Fennell Green and Bates have been involved in over 1,740 projects over the past 22 years dealing with contaminated land, ground stability issues, phase 1 contaminated desk top studies, phase 2 site investigation projects, coal mining risk assessments and soil sampling for housing, commercial and industrial developments in north of England and the Midlands. Our practice also acts as mineral advisors to several building materials companies and that work has taken our surveyors all over the UK and to Ireland, Europe, Russia, South Africa and Australia to work on a wide range of projects.

At present we are managing the remediation of a glass works tip on behalf of a client for the site to be used as housing after the materials on site have been processed and re-engineered on-site for the development platform. We have recently completed the verification of the works for a medium sized housing development in Yorkshire in a former quarry that has been backfilled with engineered fill from site.

Our team is experienced in all types of site engineering and soil management that includes materials testing that can save costs due to the re-use of these soils and a reduction in muck away.



Fennell Green & Bates
Old Joiner's Shop, 59 Oakenshaw Lane
Walton, Wakefield, West Yorkshire WF2 6NJ

Tel: 01924 255666
Mob: 07739 256461
Email: fennellgreenandbates@gmail.com
Website: www.charteredurveyorswakefield.co.uk

Events



Event Crew in Leeds & in London, UK

**We are a crewing company, for the clients, and for the crew.
We ensure the best services for you**

Olympus Crew set up in early 2018 has developed into offering event solutions with crew, technicians and carpenters nationwide. Staffing jobs and events predominantly in the north of the UK, Olympus Crew has now spread across the UK and the globe working on some of the worlds most prestigious events.

Event team Leeds and London

Whether it's a big or small event, International or Local, Olympus Crew have you covered. With crew operational in Leeds and London, with the ability to travel far and wide, we are a convenient and proficient option for you to use for your crewing needs. As well as the UK, we've sent crew to Europe, Asia, Australia, North and South America, so wherever we're needed we'll be there for you.

Here at Olympus Crew, we have a dedicated team of hardworking professionals who form the Olympus Crew family. To date, we have over 80 crew members which increases daily.

Please visit www.olympuscrew.co.uk

Contact **079 049 03452** or email info@olympuscrew.co.uk



Frequent waste extraction blockages requires system analysis

A large packaging manufacturer in Northern England endured a waste extraction system plagued by daily blockages due to 30 years of incremental changes without a major waste system review. Paramount initially addressed the issue with a small project, installing a new in-line Paramount Shoe diverter. Unlike traditional diverters, this unique design operates while waste flows and prevents blockages by avoiding trapped waste on the diverting blade.

Impressed by Paramount's performance, the customer entrusted us with a major upgrade to eliminate recurring blockages, expanding the system for new machines, and carrying out substantial service work and modifications. Paramount conducted a detailed survey, modelled the waste system using our bespoke software, and planned improvements with minimal production disruption.



System upgrades included replacing and extending ducting, adjusting diameters to optimise waste flow velocities, and installing Paramount Shoe diverters throughout. This allowed for waste segregation, enhancing returns on waste and assisting customer's sustainability targets.

Post-upgrade, the customer experiences less than one blockage per month, allowing for an investigative procedure with most now being attributed to operator error rather than system design. This work, carried out for a multi-site, multi-country producer, has not only resolved long-standing issues but also strengthened Paramount's relationship within the customer's Group through the installation of proven, tested solutions and Engineering expertise.

T +44 (0)127 669 1463
<https://paramountwaste.co.uk>



WASTE EXTRACTION SYSTEMS FOR ALL TYPES OF DRY WASTE, DUST AND FUMES



With 25 years experience, Paramount Waste Extraction Ltd. specialises in designing, installing, and upgrading waste extraction systems tailored for a wide range of industrial, process and manufacturing sectors, including carton manufacturing, printing, packaging, foil and film production.

With a focus on efficiency and sustainability, Paramount Waste offers custom solutions to optimise waste handling, reduce production downtime, and enhance operational productivity with automated systems. Our services range from complete turnkey installations to system assessment, modifications and upgrades.

A complete range of proven designs including Chopper Fans, Separators and Filtration equipment combine with many years experience to create efficient and effective designs that work.

Paramount Waste collaborates closely with clients to ensure each project is completed within budget while delivering lasting improvements. Known for our expertise and commitment to quality, we provide dependable solutions to meet all types of modern industrial waste handling challenges.

Contact us on;

+44(0)127 669 1463

enquiries@paramountwaste.co.uk

WWW.PARAMOUNTWASTE.CO.UK



Introducing the Eco Clipper Electric Mowing Systems

Eco Clipper offers large area mowers that help field managers minimise mowing costs while producing a professional finish. The Eco Clipper mowing system was originally developed to replace the cylinder mower in turfgrass production. The aim was to retain the cutting performance of a well-tuned cylinder mower, but not the high maintenance requirements and sensitivity to mowing conditions, such as wet grass and weeds.

The system

The smooth cutting decks with fast spinning small blades ensure a high quality of cut and a good distribution of clippings. Thanks to the electrically driven blades, the mower is very economical and quiet. The large wheels and smart mower deck linking system ensures good contour following and enables high mowing speeds.



The benefits

Users report high productivity gains and appreciate the low maintenance requirements and the ability to schedule mowing even under less favourable mowing conditions, such as early morning dew and wet autumn, which can often prevent removal of grass clippings.

The models

Municipalities and sports field and park managers have discovered the advantages of the Eco Clipper mowing system. For them, Eco Clipper now offers two versions: the 4.11m wide EC-FM4 Sport and the 3.43m wide EC-FM343. Both are positioned in front of the tractor, providing excellent visibility and comfort for the tractor driver.

The EC-FM4 Sport has four independent mowing decks, mows till 4.11m wide and folds up to 2.5m width. It only needs 50hp, but fits best to small size agricultural tractors. To meet the demand for more lightweight mowers suitable for most park tractors from 40hp upwards, the Eco Clipper FM343 has been developed. This three-part Eco Clipper front mower cuts 343cm wide and folds to a transport width of 170cm. As with the larger 411cm wide EC-FM4, electricity is provided by a PTO-powered generator behind the tractor.

For more information, please see below:
info@ecoclipper.com
<https://www.ecoclipper.com>



Storage Space

Creating perfect sleep and storage solutions

Wallbed Systems offer an exclusive range of beautiful wall bed hardware designs to furniture manufacturers and retailers, hardware distributors and retailers, hotel and hospitality contractors



around the world. This sleeping solution works perfectly in hotel rooms, micro-apartments, small bedrooms, a home office and student accommodation, providing an excellent hybrid living, working, studying and sleeping area, fully maximising the space available.

opportunities for sensible designs of reliable, safe and flexible wall beds, which could feature comfortable mattresses. With the latest designs and accessories (such as with the Alpha bed and Studio desk pairing) small or odd shapes rooms are transformed into multi-use spaces with cleverly concealed sleeping areas.

Wallbed Systems Ltd. is a London-based global business established by Managing Director, Jeremy Waller, who has extensive experience selling mattresses and beds across Asia, who saw

Contact Jeremy Waller,
T +44 (0)208 704 5796
T +44 (0)7780 661958
jeremy.waller@wallbedsystems.co.uk
www.wallbedsystems.co.uk

WBS WALLBED SYSTEMS
 Let's build a Wallbed together

next bed™

LEADING FOLDAWAY BED SUPPLIERS

Wide Range

Highest Quality

Competitive Prices

Wallbed Systems designs, develops, manufactures and distributes a wide range of wall bed designs to 27 countries around the world

Contact +44 (0)208 704 5796 | +44 (0)7780 661958
www.wallbedsystems.co.uk | jeremy.waller@wallbedsystems.co.uk

Compliance Solutions



CheckedSafe was developed to provide simple and inexpensive compliance solutions that could be tailored to any industry.

T 01282 908429
info@checkedsafe.com
www.checkedsafe.com

Timber



The Company was founded in 1883 by Louis Vandecasteele. In those days, wagon making was the main commercial activity. Desiré Vandecasteele, son of the founder, then added a small sawmill.

Contact
T +32 56 43 33 00
vandecasteele.be/en

Machinery





With 35 years of experience in the access industry, we will find the platform most suited for your needs and supply at the best price achievable.

Independent Access Sales offer a complete service management facility throughout the UK.

T 07483 246878
enquiries@iasales.co.uk
iasales.co.uk

Landscaping Machinery

Eco Clipper offers large electric-powered mowers that help field managers minimise mowing costs for sports fields. Users report high productivity gains and appreciate low maintenance requirements, quiet operation and the ability to schedule mowing even under less favourable mowing conditions, such as early morning dew and wet autumn.

T +31 (0)6 46 75 35 60
www.ecoclipper.com

Engineering & Consultancy



Bartels & Vedder is an engineering firm, specialised in floating and flood proof buildings and structures.

T +31 (0)6 422 398 53
www.bartelsvedder.nl

Waterproofing



TuffStuff® is the UK's premium designer, manufacturer and supplier of heavy-duty GRP waterproof flat roofing systems.

T 01977 680250
orders@tuffwaterproofing.co.uk
www.tuffstuff.co.uk

Fixings



Our Award Winning Solutions are one of the most cost-effective solutions to enable the fitting of external furniture through external wall insulation and rain screen cladding, with the added benefit of being designed specifically for the job.

T 01884 211540
info@swifix.co.uk
www.swifix.co.uk

Storage



Wallbed Systems offers a large range of wallbed hardware designs. We produce many different styles of wallbeds and ship all over the world.

Contact Jeremy Waller,
T +44 (0)208 704 5796
jeremy.waller@
wallbedsystems.co.uk
www.wallbedsystems.co.uk

Hinges



GOLD & WASSALL
EST. 1790

Gold & Wassall have been manufacturing hinges for over two centuries, so it's safe to say we know what we're doing.

Our team of experts can design and manufacture almost any hinge, for any application.

T 01827 63391
sales@goldwassalhinges.co.uk
www.goldwassalhinges.co.uk

Project Management Software



elevateTM
Construction Made Easy

Elevate software can provide real-time updates, directing everyone on actions and this results in the team, prioritising their time and becoming more productive.

www.elevate-software.co.uk

Interior & Exterior Furniture



BESPOKE CRETE

BespokeCrete creates custom and bespoke furniture, outdoor kitchens, kitchen worktops, waterfall islands, patio sets, indoor table & bench sets, coffee tables, baths, sinks and so much more – that is fully waterproof, heat, stain and scratch resistant.

T 0800 061 4157
info@bespokecrete.com
www.bespokecrete.com

Deephole Drilling



UNISIG
DEEP HOLE DRILLING SYSTEMS

Our industry-leading customers around the world rely on UNISIG® deep hole drilling technologies for powerful, productive solutions and value. We engineer our machines to handle a complete range of applications, and support them with our high level of expertise and service.

www.unisig.com

Safety Consultancy



DCON
SAFETY CONSULTANTS

DCON Safety Consultants is committed to understanding the specific needs, goals, and desires of each individual client and project.

T +353 (0)1 611 1556
info@dconsafety.com
dconsafety.com

Sign Plaques & Architectural Castings



LEANDER
ARCHITECTURAL

Manufacturers and designers of high quality fingerpost signs, bandstands, bespoke canopies, Porte-cochère, blue plaques, noticeboards, cast signage, memorial plaques, street furniture, gazebos and much more.

T 01298 814941
www.leanderuk.com

Portable Buildings



ModConCabins
Manufacturer of Modular, Containers & Cabins

ModCon Cabins provides modern, affordable and bespoke modular and portable buildings for a multitude of situations, each one carefully crafted from new and used shipping containers.

T 0333 404 8822
modconcabins.co.uk

Eco-Friendly Plastic Products



KEDEL TRADE
ECO-FRIENDLY PLASTIC PRODUCTS

Kedel Limited is a family business, founded on ethical and ecologically sound principles.

We created our business to showcase the very best recycled plastic products, putting green, sustainable living at the heart of all our company decisions.

T 01282 861325
www.kedel.co.uk

LE TONKINOIS VARNISH



LE TONKINOIS VARNISH IS A NATURAL OIL BASED YACHT VARNISH, USING A CHINESE FORMULA DATING BACK TWO OR THREE CENTURIES. AND WHAT A FORMULA!

IT REMOVES YOUR BRUSH-MARKS, BRINGS OUT THE NATURAL BEAUTY OF THE TIMBER, DOESN'T CRACK OR FLAKE OFF, AND IS PERMANENT, SIMPLY ADD A FURTHER COAT EVERY FEW YEARS.

Click here
ebay

Please visit www.letonkinoisvarnish.co.uk
Telephone 01628 629892 or email mail@letonkinoisvarnish.uk



Continuous Remote Monitoring



Three years time storage
3 years rolling data retention



Live dashboards
Create real-time dashboards
to analyze data and control devices



Events engine
Keep operators on-the-ball
and informed



Synthetic Variables
Transform raw data into insights



User management
Build applications to best fit
the operator's needs

Interface Force Measurements Ltd

Ground Floor, Unit 19, Duke's Ride, Wellington Business Park
Crowthorne, Berkshire RG45 6LS

Tel: +44 (0)1344 776666 | Email: info@interface.uk.com | www.interface.uk.com

New UNISIG Operating System Streamlines the Human-robot Interface

Representing a leap forward in programming, UNISIG's next-generation operating system further improves the human-robot interface and slashes programming times.

The new operating system, featured on UNISIG's UNE6-2i-750-CR small-diameter gundrilling machine, streamlines the setup of dozens of different part handling combinations to reduce new part setup times by 80% or more. The system significantly improves the communication between the machine's human machine interface (HMI) and the robotic controller. This enables centralized data storage or a single source of truth – the coding and data for the gundrilling operation and the program for the part handling are stored together for ease of recall.

Because it works within a parametric programming environment, the new operating system automatically adjusts its parameters to any dimensional part changes, without the need to manually calculate and enter in new

parameters. Such intelligence eliminates the need to start over and create entirely new and independent programs, while greatly simplifying and shortening programming times for part families.

The UNE6-2i-750-CR gundrilling machine with integrated robot ships with a handheld programming console/teach pendant connected to the machine. Prior to the use of parametric programming, all part handling operations were pre-programmed using the pendant. Users can now enter and store all machine and robotic parameters in the machine HMI. This allows for a more centralized user experience and greatly reduces the depth of robotic experience required.

The machine HMI has built-in parametric selection guides, allowing users to toggle between data entry and the programming guides. Each data value, and its function, are graphically displayed in the on-screen programming guide. This prevents the guide from being misplaced and makes it available

at all times, which is especially advantageous when periodically adding new parts involving large time gaps between them.

The UNE6-2i-750-CR with integrated robotic automation also features interchangeable part trays. The robot services both the machine's spindles and accommodates drilling of different diameters from each end. The optional lantern chuck system on this machine model allows workpiece loading into the rear of an automatic collet chuck to ensure accurate workholding, especially for uniquely shaped workpieces.

UNISIG's UNE6 Series of precision gundrilling machines generate holes from 0.8mm to 6.0mm (0.03" to 0.24") in even the most challenging of materials. Such capability makes the machines well suited for a wide range of applications, including medical part manufacturing.

T +49 (0)7125 9687590
info@unisig.de
<https://unisig.com>





UNISIG

UNISIG TAKES YOUR GUNDRILLING PRODUCTION FURTHER

Gundrilling and BTA deep hole drilling for highly productive shops.

Whether your shop needs on-center or off-center holes, specialized job shop work or fully automated production, UNISIG has a deep hole drilling solution with the accuracy and performance you need.

Take your shop's production further - learn more at UNISIG.COM.



Machines • Tools • Automation

UNISIG machines, engineered and manufactured in the USA

UNISIG
DEEP HOLE DRILLING SYSTEMS

CAMB MACHINE KNIVES

"A Cut Above the Rest"

QUALITY IS OUR GUIDING PRINCIPAL

With over 34 years of experience supplying the machine knives industry. CAMB Machine Knives was established in the UK in 1989 and aimed to provide consistently high quality knives and service to a broad range of industry sectors. Based on these guiding principals, CAMB Machine Knives has flourished and grown throughout Europe, USA in 25 countries worldwide establishing a reputation for high quality products and service.

CAMB MACHINE KNIVES INTERNATIONAL REACH

CAMB Knives International really does have an international reach with a network of exporters and carriers - with offices both in the UK along with agents in Spain, Netherlands, Italy, Germany, South Africa and many more so you'll never be far away from a CAMB Knives representative.

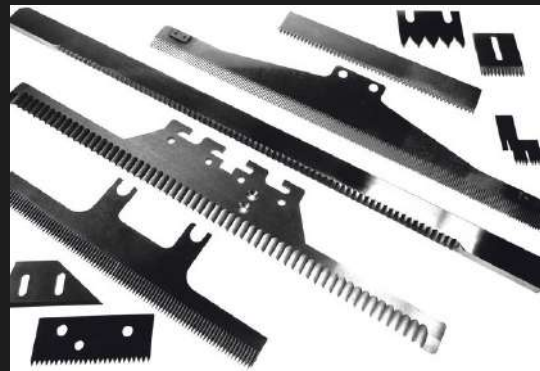

KNIVES FOR INDUSTRY - WE'LL SUPPLY IT

Our range includes many types of blades, but not limited to:

CIRCULAR KNIVES

GRANULATOR KNIVES

POULTRY KNIVES

RAZOR BLADE KNIVES

STRAIGHT KNIVES

TOOTHED KNIVES

TRAY FORM KNIVES

TOP/BOTTOM KNIVES

ZIG ZAG KNIVES

CAMB MACHINE KNIVES INTERNATIONAL LTD

Tel: 01454 322178 | Fax: 01454 321172

Email: sales@camb-knives.co.uk

www.camb-knives.co.uk

MANUFACTURERS AND DISTRIBUTORS OF MACHINE KNIVES TO ALL INDUSTRIES



75 years of W J Horrod Ltd

This year, W J Horrod Ltd, an award-winning, family-owned business, proudly celebrates 75 years!

Founded in 1950 by brothers William John and Alex Horrod, W J Horrod Ltd began as a repair service, leveraging their military engineering experience. It quickly evolved into a leading manufacturer of asphalt and bitumen equipment, as well as civil engineering and highway maintenance machinery.

Incorporated in 1961, the company was named after their father William John Horrod Snr, whose financial support made it possible. Over the years, it remained a family business, with younger brothers and later generations taking the helm. Today, second-generation directors Kim and Terry run the company, with third-generation apprenticeship to carry on the legacy.

For 75 years, W J Horrod Ltd has been at the forefront of manufacturing equipment for industrial solutions. Based in London, the company is widely recognised as the industry leader in safety and efficiency.

Horrods thrive on challenges: continually developing, designing, and testing new products to ensure customers have the very best machinery and plant for each project. Over the years, Horrods has worked across mainly the 'building' industry, but its expertise is not strictly



limited to it. The company has provided all manner of products for manual handling, with clients ranging from the Royal Opera House, to the QEII Conference centre and Billingsgate Market. Their product range is extensive, and includes everything from the SwiftMelt Mastic asphalt mixer to Hotboxes, Hot Air Rubber Materials melters, and thermoplastic pre heaters (whiteliners.)

Always at the forefront of safety, quality and efficiency, Horrods' range of services also include operator training, a

hire service for many of its products, consultation on heating/decanting of new materials, research & development for problem solving, health & safety, and the ability to collaborate with Health & Safety Executives.



Terry Horrod Snr truly championed health & safety and advised HSE on good practices until the early 2000's. Safety continues to be the watch word at Horrods today, as many of the larger products have moving parts using LPG Propane Gas or electric elements, and are heating vessels that produce hot materials.

Working alongside AYM, Horrods takes safeguarding very seriously, prioritising safety alongside quality. Every product is crafted using the highest-quality components and undergoes a rigorous design process, including longevity testing. Additionally, they ensure that products are easy to service and monitor once they leave the workshop.



For more information, please contact the team on the details below:
T 020 8539 5746
<https://www.wjhorrod.co.uk>



75 Years of Research & Development have allowed us to hone our expertise and to produce design and engineering excellence

W J Horrod Ltd has been manufacturing equipment for the roofing industry since the late 1950s.

Recognised as the leading manufacturer for Safety and Efficiency, Horrods is a family owned business based in London, as it has been for its 75 year existence.



2 Drum 110 Volt Electric Agitation model gas-fired

SMS Thermostat Control Bitumen Boilers



Swiftmelt Mastic & Specialist Asphalt Mixer



Safety Melt Series 4: Thermostatically Controlled Bitumen Boiler



For more information, please visit www.wjhorrod.co.uk
 Contact **020 8539 8746** or email kim@wjhorrod.co.uk



The UK's number one sealing solutions provider

Service Sealing Solutions Ltd provide a number of different sealing solutions across the UK to both the public and private sectors. As the sole UK distributor for the sealing industry's top manufacturers; DOYMA and HKD, Service Sealing Solutions Ltd specialises in high-quality service duct sealing systems for utility services and watertight seals.

Service Sealing Solutions Ltd has the exclusive rights to distribute DOYMA products in the UK. DOYMA stands on the front line when it comes to the development of innovative, practical solutions for sealing and fire systems. Providing the very best in German engineering, DOYMA is used to seal penetration points in walls and floors to permanently prevent any infiltration of gases and water into the building. All DOYMA products are designed to solve all watertight duct sealing requirements, prevent against structural damage and incorporate rubber mouldings that ensure all gas and watertight features.

Demanding building types, such as power plants, large industrial plants, reservoirs or airports, often require highly specialised

custom-made constructions. They place high demands on the fact that building penetrations such as cables and pipe work need to be permanently sealed. In the case of extraordinary pipe dimensions or special thermal, chemical or physical requirements, sealing systems in the form of a special construction are the required solution.

Service Sealing Solutions Ltd has a large range of DOYMA products that come with a 25-year warranty. DOYMA product brochures are available on the website and include products that have been supplied to some of the UK's largest projects such as HS2 and Kings Cross in London. DOYMA has recently released its new generation Curaflex Nova® gaskets, which are the perfect solution for any professional tradesman instantly looking to solve sealing problems and can be adapted to multiple applications.

Service Sealing Solutions also supplies HKD products, which are now owned by DOYMA. HKD manufacture a large range of pipe sealing systems and service conduits that are guaranteed to withstand up to four bars pressure. HKD systems have a sealing solution for service



Husband and wife team, Jim & Tina have recently visited DOYMA in Germany to find out about the innovative products that DOYMA have been developing

conduits cast into concrete without the sleeves. They are supplied and ready to use, requiring no site preparation work prior to installation. With options such as KE Socketless service conduits, KG Wall Ducts and Floor Ducts, together with KG Twin Sockets for installation in pump sumps, HKD products are ideal for situations where suitability for thin-walled concrete structures is vital.

For more information, please see below:
T 01952 510050
www.servicesealingsolutions.co.uk



Service Sealing Solutions Ltd - suppliers of DOYMA products



Service Sealing Solutions Ltd are the sole UK distributor of DOYMA products. Wherever services are installed through walls, ceilings or floors, penetrating water may cause damage to buildings. Lack of attention to the points of entry of pipes and cables into the building can have serious results: damp cellars, equipment damaged by water ingress and high repair costs. Service sealing systems ensure professional and perfect pipe sealing, thus presenting excellent preventative measures against structural damage. The very best in German engineering is used to seal penetration points to the wall to permanently prevent any infiltration of gases and water into the building, and the duct sealing systems are guaranteed for 25 years. Service Sealing Solutions supply the full range of products to suit all situations for power cables, communication cables, pipes and ducts, and specialising in sealing district heating pipes.

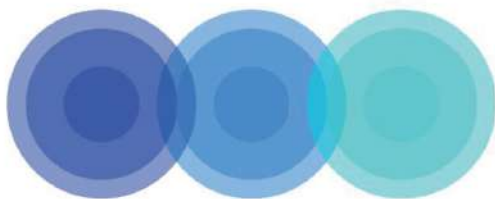

Service Sealing Solutions Ltd



**01952 510050 | www.servicesealingsolutions.co.uk
sales@servicesealingsolutions.co.uk**

Prefabricated Portable Buildings

Premium prefabricated portable building blocks and more

Arkem Leisure Ltd, based in Staffordshire, are the UK's leading manufacturer and supplier of premium portable toilet and washing facilities for Campsites, Caravan Parks, Holiday Parks, Marinas, and Sports & Leisure facilities.

A clean, well-maintained toilet and shower block is a major attraction for customers seeking a comfortable 'home from home'



experience. If you're considering replacing or upgrading your current brick-built facilities, Arkem Leisure offers the expertise and creative flexibility to build according to your precise specifications. From size and colour to interior details, Arkem ensures every requirement is met - saving you both time and money. The full range of unisex showers and toilet blocks can be found on the website, and all come with optional extras.

However, Arkem Leisure doesn't just stop at toilet and shower blocks, they also create beautiful Luxury Lodges. Each Lodge can be made completely bespoke to your needs, whether you want one, two or three bedrooms, as well as elegant kitchens and living spaces featuring log burners and recessed TV screens.

T 01543 524553
info@arkemleisure.com
<https://arkemleisure.com>



FACILITIES TO COMPLIMENT YOUR BUSINESS

UK's #1 SUPPLIER OF PREMIUM PORTABLE TOILET & SHOWER BLOCKS



TOILET & SHOWER



ACCESSIBLE TOILET & SHOWER



TOILET ONLY



GET IN TOUCH TODAY!
01543 524 553
info@arkemleisure.com
www.arkemleisure.com

THE POSSIBILITIES ARE ENDLESS...

Each block is completely bespoke, meaning you can decide on the layout that best matches your needs.

Join us at stand FS.1104/9
with Electroelsa 10TH, 11TH
& morning of the 12TH

April 7-13, 2025,
Munich



bauma

DIRECT HOIST

OFFICIAL UK DISTRIBUTOR OF
ELECTROELSA HOISTS & MASTCLIMBERS

Electroelsa

- ▲ HIRE
- ▲ SALES
- ▲ SERVICING
- ▲ PARTS
- ▲ REPAIRS
- ▲ TRAINING

DIRECT HOIST DIRECT HOIST



CELEBRATING
10 YEARS
PROVIDING
HOISTS FOR
CONSTRUCTION

DIRECTHOIST.CO.UK

Biogas & Ventilation



Specialising in quality equipment for tank storage, process safety, and fluid transfer, we offer dedicated maintenance and expert technical support. Rooted in our commitment to you and the environment, we champion emission reduction and quantification, merging efficiency with ecological accountability.

T +44 (0)1726 844707
info@assentech.co.uk
www.assentech.co.uk

Farming



A small 18-acre working family farm in the market town of Oakham, the county town of Rutland, England's smallest county.

T 01572 722122
admin@rutlandfarmpark.co.uk
www.rutlandfarmpark.co.uk

Roofing



We have been at the forefront to design, innovate and manufacture materials and products to make buildings and flat roofs watertight. As the world above and below the roof is constantly changing, so do we to adapt and offer sustainable, durable and easy-to-install roofing and facade systems.

T +44 (0)1623 627285
info.uk@ccm-europe.com
www.ccm-europe.com/gb

UK Machinery



Machine Operators – Software Engineers
 – Electronic and Hydraulic Engineers

We have an excellent skill force and team to back up our sales with 24/7 Support Network.

Over 35 Years of experience.

T 01482 420491
info@ukmachinery.uk
www.ukmachinery.uk

Marine, Offshore, Chemical, Oil & Gas



MiB is a product/service that builds in diagnostic support for multiple assets via Machine Learning and Artificial Intelligence.

T +44 (0)7422 079140
simon.edmondson@
cmservicesglobal.co.uk
maintenance-in-balance.com

Noise & Vibration Measurement



We manufacture and supply high-quality acoustic measurement instrumentation. Cirrus Research is dedicated to the prevention and eradication of noise-induced hearing loss and environmental noise pollution.

T +44 (0)1723 891655
https://cirrusresearch.com

Metal Improvements



Curtiss-Wright surface technologies provides customers a single-source solution and point of contact for all their controlled material surface treatments, supporting their requirements through our global network of over 70 worldwide facilities and on-site field teams, improving and reducing turnaround times and costs.

T +44 (0)1635 279621
eurosales@cwst.com
www.cwst.co.uk

Industrial Applications



Working with light since 1931, CML is the market leader in the field of miniature lighting for signalisation. As one of the first companies to introduce LED lamps, nearly 30 years ago, CML is now the supplier with the broadest range of miniature lighting products in the world.

T +44 (0)1284 714700
uksales@cml-it.com
https://cml-it.com/en

Ocean Power & Monitoring Systems



With more than 15 years of experience, SubCtech has established its position among leading manufacturers for Ocean Power and Monitoring systems.

T +49 (0)431 220 39880
<https://subctech.com>

Air Pollution Control Systems



Providing specialist industrial air pollution control, gas treatment and odour control packages – turnkey supply of the complete system: design, supply, installation and commissioning – all backed by a process guarantee.

T 01403 290000
info@ergapc.co.uk
www.ergapc.co.uk

Deep Hole Drilling



Our industry-leading customers around the world rely on UNISIG® deep hole drilling technologies for powerful, productive solutions and value. We engineer our machines to handle a complete range of applications, and support them with our high level of expertise and service.

T +49 (0)7125 9687590
<https://unisig.com>

Electrical Products



The SIMONBOX IP66 watertight floor box is designed for use in hard floor areas which require occasional power and data connection and an IP protection rating. Typical ip66 waterproof floor box installations include Department Stores, Airports, Train Stations and Car showrooms.

T 0203 286 7949
simonbox.co.uk

Sealing Solutions



Service Sealing Solutions are the sole UK distributor for the sealing industry's top manufacturers; DOYMA and HKD.

Contact
T 01952 510050
www.servicesealingsolutions.co.uk

Measurement Applications



Interface Force Measurements Ltd is the master distributor for Interface load cells in the UK, Ireland, Middle East and North Africa. While we are separate companies, our interests and values are closely aligned in a long-term commercial relationship spanning over 30 years.

T +44 (0)1344 776666
interfaceforce.co.uk

Emission Monitoring & Gas Control



ECO PHYSICS AG offers innovative analytical solutions for measurement tasks in the fields of environment, health and process control.

T +41 55 220 22 22
info@ecophysics.com
www.ecophysics.com

Hand Protection



Manosun hand protection want to bring a change to the end-user experience in selecting and buying industrial gloves, gauntlets and sleeves (PPE).

Contact
T +44 (0)191 300 8699
sales@manosun.co.uk
www.manosun.co.uk



Rutland Farm Park is a small 18-acre working farm in the market town of Oakham, the county town of Rutland, England's smallest county.

We are open all year round for you and your family to explore our tracks and meet and feed our wonderful and friendly animals.

Admission Prices
Farm Park Admission

Adult 13+	£10
Child 3-12	£9
Under 3	Free
Family ticket	£35.00
Visitor with support needs with carer	£15

(2 Adults and 2 Children/1 Adult and 3 Children)
We offer 10% Military discount with a valid ID
(Annual Passes Available)

Opening Times
Summer

Tuesday - Sunday 10am-5pm
(Last entry at 4:00pm)

Winter

Open on Bank Holiday Mondays
and School Holidays
Closed Christmas Day and New Years Day



Please visit www.rutlandfarmpark.co.uk,
contact **01572 722122** or
email info@rutlandfarmpark.co.uk

