



# INDUSTRIAL SOLUTIONS UK

ISSUE 683 • February 2025

[www.solutionspublishing.co.uk](http://www.solutionspublishing.co.uk)  [www.facebook.com/solutionsuknews](https://www.facebook.com/solutionsuknews)  @Publishing\_2016

**CELEBRATING 75 YEARS**  
see page 21



**PREMIUM PREFABRICATED PORTABLE BUILDING BLOCKS & MORE**  
see page 22



## LEADING LASER WELDING & LASER CLEANING TECHNOLOGY

Laser welding machines are used to join thin metal sheets with minimum heat input and the joining of differing metals, offering precision advantages for intricate designs and delicate materials.

see page 24

### IN THIS ISSUE

**SubCtech**  
see pages 4-5

**UNISIG**  
see pages 6-7

**Eco Physics**  
see page 8

**ERG**  
see page 9

**RM Fowler**  
see page 10

**Cirrus Research**  
see pages 12-13

**Interface Force**  
see pages 14-15

**Service Sealing Solutions**  
see pages 18-19

### BUILDING UPDATE

**Checkedsafe**  
see pages II-III



# Contents

Issue 683 • February 2025

## Whats Inside



6-7

**UNISIG**  
Deep Hole Drilling



9

**ERG**  
Industrial Gas Cleaning &  
Thermal Systems



16

**CML Innovative Technologies**  
LED Signal Lamps for all  
Industrial Applications



20

**Direct Hoist**  
Hoists



21

**W J Horrod**  
Manufacturing

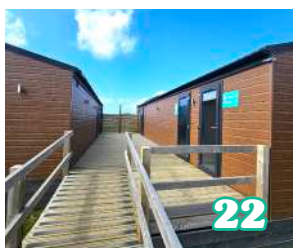

22

**Arkem Leisure**  
Prefabricated Portable Buildings

## On the Cover

Machinery Supplies UK



24

## Editors Comments

### Hello & Welcome to Issue 683 of Industrial Solutions UK!

The team at Industrial Solutions UK has been working extremely hard to bring you an issue that is full of innovative and exhilarating companies and we are very excited to share their success and achievements with you.

We have searched the length and breadth of the UK to bring you some of the most ground-breaking innovations and this month, we are overjoyed to be highlighting the activities of WJ Horrod, RM Fowler and Arkem Leisure.

Firstly, we would like to focus on the accomplishments of RM Fowler who this month features under 'Controls, Drives & Automation,' **please see them on page 10.**

Secondly, we are featuring WJ Horrod with the **'75 Year Milestone in Industry'** profile following their impressive performance over the years. **For more information, turn to page 21.**

Lastly, we would like to highlight Arkem Leisure for their portable building blocks that can be developed for different purposes. **These can be seen on page 22.**

I hope you enjoy reading this issue of Industrial Solutions as much as we have enjoyed bringing it to you. Happy reading and we hope to see you for the next edition!

**Ian Hayward, Editor**  
INDUSTRIAL SOLUTIONS UK

## Contacts

**Editorial**  
Ian Hayward, Editor  
T 0121 241 8788  
info@solutionspublishing.co.uk

**Accounts**  
Accounts Manager  
T 0121 681 0935  
accounts@solutionspublishing.co.uk

**Production**  
Production Manager  
T 0121 241 8788  
production@solutionspublishing.co.uk

Industrial Solutions UK is based on the belief that our customers needs are of the highest priority and the utmost importance, with this in mind our team of highly dedicated staff work around the clock to make sure that those needs are always met.

For more information or format requirements, please see our **Media Pack.**

For all advertising & sales enquiries, please contact Ian Hayward on: **0121 241 8788**, email: **info@solutionspublishing.co.uk** or visit: **www.solutionspublishing.co.uk**

FIND US ON:



## BUILDING UPDATE



**Checkedsafe**  
Compliance Solutions **II-III**



**Playcraft Group**  
UK Manufacturers **IX**



**Warwick Buildings**  
Timber Buildings **X**



**Kedel**  
Eco Friendly Plastic Products  
– Top Recommendations **XVI**

Sponsored by **UNISIG** on pages 6-7  
DEEP HOLE DRILLING SYSTEMS

**CURTISS -  
WRIGHT**

# Surface Technologies



- Controlled Shot Peening
- Laser Peening
- Keronite PEO
- Thermal Spray Coatings
- Dry Film Lubricants
- Organic and Inorganic Coatings
- Parylene Ultra-thin Conformal Coatings
- Superfinishing
- On-site Processing
- Material Testing and Analysis
- FAA, AS9100 Rev D, NADCAP, ISO9001:2015



**www.cwst.co.uk • eurosales@cwst.com • 01635 279621**

## Innovative Technologies and Sustainable Measurement Strategies for the Marine Environment

In this issue of Industrial Solutions, we are happy to feature award-winning SubCtech (Subsea Technologies for the Marine Environment) a leading manufacturer of underwater technologies for its Commitment to Excellence in Ocean Power and Monitoring Systems.

Established in 2010 by Applied Physicist: Stefan Marx (CEO), the maritime powerhouse is based in Kiel, Northern Germany. With a diverse team of expert mechanical and electrical engineers and software specialists, this medium-sized company is committed to next-generational R&D, bespoke project consultation, rigorous testing of prototypes and first-class manufacturing.

Under the expert guidance of Stefan Marx, the company is divided into two specialised sections: Ocean Power Products and Ocean Monitoring Equipment offering a range of products tailored for various marine and subsea applications.

The Ocean Power Products are supplied primarily to customers in offshore oil & gas companies, monitoring stations/moorings, subsea applications and autonomous underwater vehicle (AUV), remotely operated vehicle (ROV) manufacturers. The Li-Ion battery systems (PowerPacks) range from standard, subsea, vehicle, customised batteries, chargers to battery-management systems (BMS.) The advanced-precision titanium housing is fully customised and can be used for depths up to 6,000m.

The subsea batteries, for example allow high-performance for a design life of 25 years, with the electronic and Li-Ion cells meeting meticulous, optimised safety standards. The rechargeable Li-Ion batteries provide robust subsea Uninterruptible Power

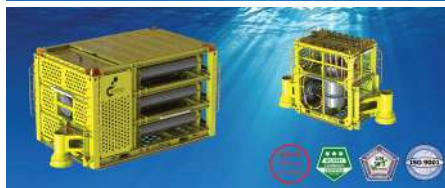

Supply (UPS) and are perfect for marine and offshore technology applications, offering next-level capacity.

"Our batteries undergo rigorous heat, shock and vibration testing, to reach the UN T38.3, MIL-STD, DNV or API17F standards of compliance and other on request," said Stefan.

The PowerPacks™ automatically protect itself e.g. at low voltage, to prevent damage, leaving operators assured of safety at all times, with the capacity to disconnect in the event of overcurrent or external short circuit. The advantage of Li-Ion batteries over Alkali primary batteries, is the high current operational features, ability to function at subzero temperatures and during high currents/peaks. Furthermore, the corrosion-free titanium housing can be used up to depths of 6,000m. The batteries are used for industrial applications and are tested in accordance to API17F, MIL-STD, DIN-EN and DNV – according to the application.

The ocean monitoring equipment provided by SubCtech is essential for scientific institutes, researchers aboard vessels, and sailors. This equipment facilitates comprehensive monitoring of surface and subsea

environments, focusing on greenhouse gas levels and micro-plastic sampling. The flagship product, the Autonomous Underway Measurement System (AUMS), is specifically designed for pCO<sub>2</sub> monitoring on 'Ships of Opportunity.' It is highly versatile and can be enhanced with additional sensors, such as the Meteo Top-Box for Sea-Air Exchange flux measurements and other third-party instruments.

The latest Microplastic Sampler for example, offers autonomous monitoring on any type of sea vessel and can detect even the smallest presence of microplastics in the water, down to particles per m<sup>3</sup>. The next-level robust, waterproof design provides accurate sampling, even on high-speed boats travelling at 30kn.

Stefan said, "We are experiencing rapid growth in our industry, driven by high demand for our Ocean Power products. We serve customers globally, including Europe, Asia, Australia, and the US, ensuring safe transport of our UN T38.3 certified Li-Ion batteries worldwide via airline cargo."

"Our professional sales partner network streamlines service delivery across regions. In response to exponential growth, we've nearly doubled our staff to 76 and plan to expand our facility from 1,200sqm to 4,000sqm."

"We prioritise environmental sustainability, using LED lighting, promoting public transport, and recycling all components, including batteries. Our Microplastic Sampler aids scientists in monitoring ocean microplastic pollution, which affects marine life and human health."

"Our latest innovation, the Subsea 2 MWh Energy Storage System has now successfully passed its final field-testing stage: the system has been commissioned and tested in situ and, therefore, has already reached the Technology Readiness Level 6 (TRL 6), according to API17Q, which exemplifies our commitment to high standards."

"Looking ahead, we aim to lead in Subsea and Ocean Power Solutions and Ocean Monitoring Systems globally. We seek strategic partners and are eager to expand our network within the international Oceanology sector."

For more information, please see the website below:  
T +49 (0)431 220 39880  
info@subctech.com  
www.subctech.com

# Ocean Power

Transform into the cost-efficient and sustainable future



## Li-Ion PowerPack™ - Underwater power solutions

Highly reliable, efficient and safe Li-Ion batteries - Made for harsh offshore and subsea conditions!

Energy Storage Systems

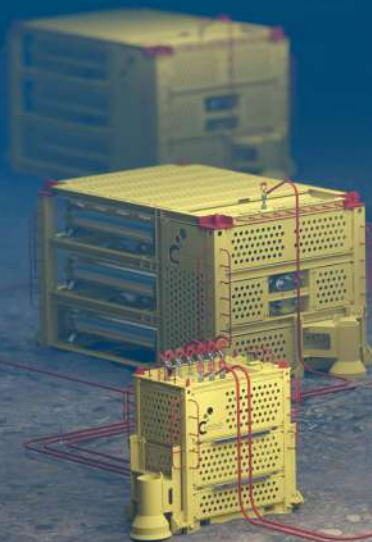

Vehicle Batteries



String Batteries



Subsea UPS



[www.subctech.com](http://www.subctech.com)



# New UNISIG Operating System Streamlines the Human-robot Interface

Representing a leap forward in programming, UNISIG's next-generation operating system further improves the human-robot interface and slashes programming times.

The new operating system, featured on UNISIG's UNE6-2i-750-CR small-diameter gundrilling machine, streamlines the setup of dozens of different part handling combinations to reduce new part setup times by 80% or more. The system significantly improves the communication between the machine's human machine interface (HMI) and the robotic controller. This enables centralized data storage or a single source of truth – the coding and data for the gundrilling operation and the program for the part handling are stored together for ease of recall.

Because it works within a parametric programming environment, the new operating system automatically adjusts its parameters to any dimensional part changes, without the need to manually calculate and enter in new

parameters. Such intelligence eliminates the need to start over and create entirely new and independent programs, while greatly simplifying and shortening programming times for part families.

The UNE6-2i-750-CR gundrilling machine with integrated robot ships with a handheld programming console/teach pendant connected to the machine. Prior to the use of parametric programming, all part handling operations were pre-programmed using the pendant. Users can now enter and store all machine and robotic parameters in the machine HMI. This allows for a more centralized user experience and greatly reduces the depth of robotic experience required.

The machine HMI has built-in parametric selection guides, allowing users to toggle between data entry and the programming guides. Each data value, and its function, are graphically displayed in the on-screen programming guide. This prevents the guide from being misplaced and makes it available

at all times, which is especially advantageous when periodically adding new parts involving large time gaps between them.

The UNE6-2i-750-CR with integrated robotic automation also features interchangeable part trays. The robot services both the machine's spindles and accommodates drilling of different diameters from each end. The optional lantern chuck system on this machine model allows workpiece loading into the rear of an automatic collet chuck to ensure accurate workholding, especially for uniquely shaped workpieces.

UNISIG's UNE6 Series of precision gundrilling machines generate holes from 0.8mm to 6.0mm (0.03" to 0.24") in even the most challenging of materials. Such capability makes the machines well suited for a wide range of applications, including medical part manufacturing.

T +49 (0)7125 9687590  
info@unisig.de  
<https://unisig.com>





# UNISIG

## UNISIG TAKES YOUR GUNDRILLING PRODUCTION FURTHER

### **Gundrilling and BTA deep hole drilling for highly productive shops.**

Whether your shop needs on-center or off-center holes, specialized job shop work or fully automated production, UNISIG has a deep hole drilling solution with the accuracy and performance you need.

Take your shop's production further - learn more at [UNISIG.COM](http://UNISIG.COM).



## **Machines • Tools • Automation**

*UNISIG machines, engineered and manufactured in the USA*

**UNISIG**  
DEEP HOLE DRILLING SYSTEMS

## ECO PHYSICS AG develops new three-channel chemiluminescence analyser (NO/NO<sub>2</sub>/NH<sub>3</sub>)

ECO PHYSICS AG offers innovative analytical solutions for measurement tasks in the fields of environment, health and process control. Using its vital expertise and technology to contribute towards environmental preservation, human health, and industrial innovation, ECO PHYSICS' interdisciplinary research and development team work tirelessly to deliver the best customer orientated and tailor-made products and services for the industry.

Founded in 1990 through a management buy-out, ECO PHYSICS stands strong today as an independent Swiss shareholder's company with an active board of members who are committed to the future growth and success of the company. We spoke to Dr. Grischa Peter Feuersänger, Head of Sales & Marketing who explained how the past 12 months have fared.

"We have received a positive recovery post pandemic. Many public projects were reopened which generated a lot of opportunities for new references. The war in East Europe is a new tough challenge to overcome, especially for companies that rely almost completely on importing parts and exporting their finished products. But the main challenge for all of us has particularly been the manufacturing costs, shipping routes and exchange rates. Since 2022, we have used this time to expand our product portfolio and modernise our production line. New staff has



been hired for production and R&D, and we have rearranged the supply chain due to the rise in production costs. We have adapted our yearly forecast to cater to this, we know it will be hard, but optimisation is our current goal."

Knowing there is no quick fix to economic changes, ECO PHYSICS is determined to continue innovating and has developed a new three-channel analyser based on chemiluminescence. As an upgrade from the The nCLD AL2, The nCLDAL3/8555 CY analyser is the next generation in high precision nitrogen oxide measurement. Unique in speed and reliability, the nCLDAL3/8555 CY is modular designed and capable of simultaneously NO, NO<sub>2</sub>, NO<sub>x</sub>, NH<sub>3</sub> and NOX-Amines. The new and intuitive graphical user interface also individually displays and connects to other instruments' data.

Overall stability and reliability are lifted to a new level. The optional electro-mechanical bypass system balances out even the fastest

of pressure variations occurring in the sample flow. Furthermore, the analyser is adaptable to numerous non-standardised applications and the calibration of the unit runs quickly and automatically with all necessary data available anywhere at any time. Its user friendly, compact, modular, and intelligent hosting its own CPU whilst enabling interaction with other CPUs by BUS-communication.

Additionally, ECO PHYSICS has also been developing upgrade kits for all its existing products to help counteract some of the problematic complications the supply chain has caused. "We have used this chance for some substantial upgrades in hardware, software and gas flow controls," added Dr. Grischa Peter Feuersänger.

Going forward, ECO PHYSICS is excited to continue working on optimising production workflow whilst simultaneously expanding its current portfolio and developing new technologies.

In closing, we asked Dr. Grischa Peter Feuersänger how the company felt receiving our award. He responded, "We are extremely honoured to be nominated, thank you."

**Contact**  
T +41 55 220 22 22  
info@ecophysics.com  
<https://www.ecophysics.com>

### ECO PHYSICS nCLD "Facelift" boxed solutions AL<sup>3</sup> / nCLD 8555



- ✓ Compact analyzer with integrated pump
- ✓ Simultaneous NO, NO<sub>2</sub>, NH<sub>3</sub> measurement
- ✓ Internal data logger and touch panel PC
- ✓ Remote operation and POWER UP/DOWN
- ✓ USB, HDMI, LAN/WLAN, Bluetooth, RS-232, Analog I/O

Measurement of:  
NO · NO<sub>2</sub> · NO<sub>x</sub> · NH<sub>3</sub>

The three-channel chemiluminescence based NOX/NH<sub>3</sub> analyzers of the nCLD "Facelift" box-solution analyzers detect NO, NO<sub>2</sub>, NO<sub>x</sub> and NH<sub>3</sub> at concentration ranges from 0-50ppb to 0-50ppm with a minimal detection limit from 0.4ppb. The three-channel nCLD AL3/8555 includes an internal pump and the slightly modified front panel has been equipped with an additional Power-button and a new internal PC. Additionally, all nCLD-models are capable of a remote power control, including a failsafe feature. The AL3/8555 is the ideal instrument for ambient air monitoring, either installed in racks, fixed monitoring stations or mobile laboratories. The instrument's inlet operates at ambient pressure. Calibration of the unit runs quick and automatic while all necessary data is continuously stored and readily available anywhere and at any time. According to ISO EN 14211.



ECO PHYSICS AG · POB · CH-8635 DUERNTEN · TEL. +41 55 220 22 22 · FAX +41 55 220 22 55 · E-MAIL INFO@ECOPHYSICS.COM · WWW.ECOPHYSICS.COM



## ERG (Air Pollution Control) Ltd cleans up

The ERG group has over 40 years' experience and operates through three divisions. The powerhouse of the group is the first of these, ERG (Air Pollution Control) Ltd. This division has highly qualified and experienced teams of chemical, mechanical and electrical engineers who, together with design engineers, project managers and procurement professionals, design and supply bespoke gas scrubbing systems and odour control plants to meet their clients' requirements.

ERG solves the full spectrum of gas cleaning challenges facing its clients; whether it is a requirement to remove foul odours from air under ambient conditions prior to release into the atmosphere, right up to scrubbing streams of process gasses at high temperatures, high pressures, or in explosive environments to remove toxic or aggressive pollutants. The level of technical sophistication and bespoke engineering content in each project is specific to the clients' needs, with industrial applications typically demanding the highest processing technology.



The commercial driver leading clients to invest in ERG's systems might be a pressing requirement to comply with government regulations or with the emission limits set in an operating licence issued by an appropriate agency. For other clients, ERG's expertise is often sought to clean up gas streams that form an integral part of the client's production process. For example, in the green energy sector ERG's systems purify biogas or syngas that they have generated, so that the client's process runs more efficiently with lower pollution levels. In some cases, ERG's gas cleaning systems can even generate by-products, which become value added saleable side-streams.

Based in West Sussex, ERG has grown its business strongly over the years to build up a global sales network and client base.

An office in Jordan services ERG's business throughout the Middle East region, and is fully staffed with design engineers, project managers and local sales managers. A satellite sales office in Dubai completes the Middle East structure.

ERG (Plastic Fabrication) Ltd is the manufacturing division for the group and specialises in the high-quality custom fabrication of tanks, vessels, pipework and ducting from GRP and composite plastic materials, and which are used in the systems designed by ERG (Air Pollution Control). ERG (Plastic Fabrication) Ltd also welcomes commissions direct from 3rd party customers. It has a vast arsenal of services to offer clients, and has specialist experience in manufacturing using a wide range of plastic materials including PVC, CPVC, Polypropylene, PVDF, and other specialty plastics for harsh environments such as ECTFE.



Finally, the group includes ERG APC Maintenance Ltd. This division's mission is to provide servicing and maintenance support to customers throughout the lifetime of their air pollution control system. Service can be provided under contract to include a routine preventative maintenance servicing schedule designed to maintain system performance. Alternatively, maintenance can be provided on an ad hoc basis as and when required.

All three-company divisions are now based in superb new purpose-built office and factory facilities in West Sussex, which were completed in 2021. Having all divisions on the same site significantly enhances working efficiency, design quality, production quality, and production capacity.

For more information, please contact  
**ERG (Air Pollution Control) Ltd at:**  
**T 01403 290000**  
**Middle East Office +962 6515 9021**  
**info@ergapc.co.uk**  
**www.ergapc.co.uk**



## ERG (Plastic Fabrication) Ltd

At ERG (Plastic Fabrication) Ltd, we specialise in the high quality custom fabrication of process industry vessels and associated components from GRP and composite plastic materials.

With almost 40 years experience of supplying tanks, scrubbers, filters, silos, vessels, piping and ducting, we are sure to be able to meet your requirements with high quality products at competitive prices.

### Plastic Fabrication – Materials of Construction

Depending on your specific requirements we can fabricate from a wide range of common plastic and composite materials including:

- PVC – Poly Vinyl Chloride
- UPVC – Unplasticised Poly Vinyl Chloride
- PPVC – Plasticised Poly Vinyl Chloride
- PP – Poly Propylene
- HDPE – High-density polyethylene
- GRP – Glass Reinforced Plastic

For more information, call 01403 291 000,  
email [info@ergpf.co.uk](mailto:info@ergpf.co.uk) or visit [www.ergpf.co.uk](http://www.ergpf.co.uk)





**MAINTENANCE IN BALANCE, THE ONLY SOFTWARE YOU'LL EVER NEED!**

MiB is a product/service that builds in diagnostic support for multiple assets via Machine Learning and Artificial Intelligence.

MiB incorporates the diagnostic knowledge of expert diagnosticians in the conventions of mature condition monitoring techniques and aligns this with AI functionality to identify true outliers and then offer meaningful diagnostic advice.

As more assets are managed remotely and fewer onboard personnel are sufficiently experienced to deal with all scenarios, it is becoming clear that a marriage of technology and experience is needed to balance the equation.

**Objectives**

Using our asset condition assessment software MIB, we will create an integrated software platform for undertaking prescriptive maintenance on your ship's machinery, structures, and auxiliary systems. This will be achieved by using data from existing condition monitoring, diagnostic sensors and systems, the implementation of advanced predictive analytics and the integration of a maintenance actions/prescription database.

Based upon advanced, artificial intelligence (AI) and deep learning algorithms MIB will prescribe, the most appropriate maintenance strategy in real-time for every asset under its control, based on the subtle but pre-alarm indications of emerging faults that will occur at a future time.

**Specific objectives of MIB are to:**

- Establish the monitoring and maintenance needs of each vessel
- Specify the software platform parameters based on each vessel's requirements
- Deploy our intelligent monitoring software module
- Integrate the module into the MIB platform and provide routine updates to the crew

[View the MIB interview on YouTube](#)

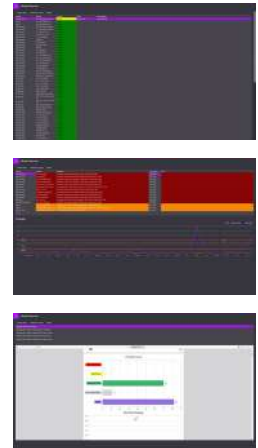

Please visit: [maintenance-in-balance.com](http://maintenance-in-balance.com) or contact UK: +44 (0)7422 079140 or Baltic: +370 (8)652 99978

**Controls, Drives & Automation**

**Linear Motion Specialists**



Authorised NSK & Nippon Bearing Distributor



**RM Fowler Ltd**

- High precision linear guides and ball screws
- NSK K1 lubricating units to extend maintenance intervals
- NH series available with high temperature design
- RA roller guides for high load, rigidity and precision
- PU/PE Miniature series with high corrosion resistance
- Precision cross roller non-recirculating slide ways
- Slide bush, Topball, Stroke bush and Ball splines
- Precision curved cross roller Gonio Ways

01565 651 051  
 sales@rmfowler.co.uk  
 www.rmfowler.co.uk



## Leading the future of Valve Technology in 2025

In this issue of Industrial Solutions, we are proud to spotlight Oliver Valves as our **Top Recommendation for Valve Technology in 2025**



Oliver Valves has grown into a global leader in valve technology, continually innovating and expanding to serve the evolving needs of the energy industry.

Comprised of Oliver Valvetek, Oliver Twinsafe, and Oliver Hydcovalves, Oliver Valves specialise in the design and manufacture of high-performance valves and related equipment.

"We provide everything from Instrumentation valves to double block and bleed valves, manifolds, needle valves, ball valves, and subsea valves. We are also a specialist in custom-engineered solutions for extreme operating conditions such as high pressure, high temperature, and corrosive environments. Our valves support both traditional fossil-based applications and newer, greener energy sources, reflecting our commitment to the emerging energy landscape," stated Joe Cooper, Marketing Manager.

As a key supplier for the hydrogen and CCUS markets, Oliver Valves has successfully completed testing for its 1,500 and 2,500 class AH fugitive emissions needle valve head units, which are now fully qualified to ISO 15848-1. This achievement not only represents a major step forward in its commitment to helping the energy sector transition to a cleaner, more sustainable future, but solidifies

Oliver Valves' position as a leader in providing high-performance valve solutions for critical energy applications.

Nick Howard, Engineering Director at Oliver Valves, commented, "This qualification not only reinforces our commitment to innovation but also ensures that our customers can rely on our valves in the most demanding hydrogen and CCUS applications."

The results and performance indicated that the valves successfully passed rigorous testing across -46°C to +85°C with over 200 cycles, meeting strict industry

standards for tightness and fugitive emissions. Both 1,500 and 2,500 class valves performed exceptionally within ISO 15848-1 limits, ensuring reliability in static and dynamic conditions. Rated Class AH, they exhibit outstanding sealing with minimal emissions, making them ideal for hydrogen electrolyser systems.

The newly qualified valves offer durability, reduced maintenance, and long-term cost savings. Their high-cycle performance extends service life, minimising repairs, downtime, and leakage, making them ideal for demanding applications requiring tight sealing and minimal emissions.

"In addition to launching new product lines, we established Oliver Hydcovalves to focus on hydrogen and carbon capture valve solutions and to support the sector's rapid technological evolution. These steps ensure we stay ahead of market demands and maintain our position as a leading innovator in valve technology," added Joe.

Oliver Valves aims to remain at the forefront of the emerging energy market - expanding its capabilities in hydrogen, CCUS, and other new energy applications, whilst continuing to redefine its product range, supporting sustainable energy projects worldwide.

For more information, please see below:  
T 01565 632636  
sales@valves.co.uk  
www.valves.co.uk



## 45 years!

As we celebrate 45 years of success at Oliver Valves, we know that none of it would have been possible without the dedication of our incredible team of dedicated staff.

Today, we want to shine a light on one of our longest-serving members, Jimmy Dalzell, who has been with us for an impressive 36 years. Starting as an assembler in 1988, Jimmy's mechanical expertise and commitment have been instrumental in some of our most significant developments, including the introduction of our ball valve, DBB, Valvetek, and Twinsafe ranges.

Jimmy's journey with Oliver Valves has been marked by countless contributions, from hands-on assembly and pressure testing of products that began as ideas and grew into industry standards. Reflecting on his career, Jimmy fondly recalls the early days, particularly as his first

interaction with Dr Michael Oliver when he humorously asked Jimmy, "Have you gone to sleep there, pal?" as he filled out his job application. It's a memory that perfectly captures the friendly and supportive atmosphere that has made Oliver Valves more than just a workplace.

The two photos below show Jimmy with Mark Oliver and Colin Bell in 1991 and again last year as they recreated the image.

Thank you, Jimmy, for your unwavering dedication and for being such an integral part of our journey. Here's to many more milestones together!

T +44 (0)1565 632636  
sales@valves.co.uk  
<https://www.valves.co.uk>



## Oliver Valves delivers key components for Shell Rosmari Marjoram project

Oliver Valves is excited to announce its latest contribution to the Shell Rosmari Marjoram Onshore Gas Package with the delivery of three different-sized valves tailored for the DS21 water treatment package.

DS21, originally a Korean company and now part of CECO Environmental based in Dallas, US, plays a significant role in this extensive project. The specialised valves from Oliver Valves are just a small part of a larger scope. Oliver Valves has also supplied the complete Double Block and Bleed (DBB) package for the Shell Rosmari Marjoram Onshore Gas Package, demonstrating their comprehensive capabilities and expertise in the industry.

In addition to the onshore components, Oliver Valves has successfully secured the offshore portion of the project through T7 Wenmax, their Malaysia agent, in collaboration with Malaysia Marine and Heavy Engineering (MMHE).

This achievement underscores Oliver Valves' commitment to innovation, quality, and excellence in the engineering sector. The company continues to be a trusted partner in delivering critical solutions for major international projects.

T +44 (0)1565 632636  
sales@valves.co.uk  
<https://www.valves.co.uk>



# Take sound to the cloud with Quantum from Cirrus Research



For more than five decades, health and safety practitioners have turned to noise monitoring equipment such as handheld sound level meters and personal noise dosimeters to assess noise levels in the workplace. However, with more and more businesses choosing to operate from multiple sites as opposed to across one site, it's possible that these more traditional methods of noise measurement and monitoring may no longer be the most efficient.

## Quantum; the future of noise measurement

Quantum Indoor from Cirrus Research is a powerful noise monitoring solution with built-in cloud connectivity, perfect for continuous occupational noise monitoring, identifying the source and type of noise that is occurring, and highlighting where noise control measures are required.

With this instrument, it has never been easier to measure and monitor workplace noise continuously and remotely across one or multiple sites.

The cloud technology that is built into the Quantum instruments allows health and safety practitioners to connect multiple noise monitors on one account, allowing for data from each noise monitor to be viewed and assessed on one platform. This creates a network of interconnected instruments, whose data can be viewed and analysed side-by-side, removing the need to download information from separate handheld instruments one-by-one.

Additionally, Quantum indoor provides a constant ear to the ground, offering live and historical data round-the-clock that practitioners can access from anywhere, at any time and on any device. Whether users are on the other side of the planet to where the instrument is installed, or they're stood in the next room, the data is always accessible on demand via the online Quantum portal, powered by MyCirrus.

With a network of cloud-connected noise monitors, the need for users to be physically on-site to measure noise levels is vastly reduced. Cloud-connected

monitors, such as Quantum Indoor, can be installed and left to do their jobs completely unattended. They can then be configured remotely to send users real-time alerts when noise events occur, which provides greater control to health and safety practitioners in the workplace.

### With Quantum Indoor, you can:

- **Link multiple units** to form a cloud-connected network of noise monitors to make viewing the full picture of your workplace noise impacts easier.
- View your **live and historical data** in the Quantum portal anytime, anywhere around the world on any device.
- Create numerous **audio triggers and notifications** based on your personal set of conditions for acceptable noise emissions, and receive these notifications via email, SMS or push notification.
- Use the **frequency analysis** screen on the Quantum portal to further view and analyse your noise data and better understand the exact nature of the noise.
- **Create detailed reports** directly through the Quantum portal based on direct data captured by your Quantum Indoor units.

### The Quantum Portal; powered by MyCirrus

With the Quantum Portal there are no fixed fees or set up charges. With Cirrus Research, users are offered subscription packages that are flexible to fit in with your noise monitoring programme and your preferred level of usage. These flexible plans means that you have the ability to change your subscription up or down on a monthly basis.

Powered by MyCirrus, this portal is suitable for all Quantum noise monitoring devices, and can also be used with other instruments such as the Cirrus Research Environmental Noise Measurement Kits.

**T +44 (0)1723 891655**  
**sales@cirrusresearch.com**  
**www.cirrusresearch.com**



### World-leading

Valves for Hydrogen, Carbon Capture, Topside, Subsea, and Pipeline Applications.

## oliver valves

### Instrument & DBB Valves

- Manifolds, Needle, Check and DBB Valves to 22.5K psi
- Cryogenic
- Severe Service 650°C, 10K psi
- Forged & Bolted Construction



## oliver twinsafe

### Pipeline Valves

- 1" to 20" Bore Size
- High Temperature
- High Pressure
- Cryogenic
- API 10K Design



## oliver hydrovalves

### Hydrogen & Carbon Capture Valves

- Instrumentation, Ball, Needle and DBB Valves for Hydrogen and Carbon Capture Applications
- Pipeline Ball Valves upto 18"
- 10K Ball Valves for Hydrogen Fuelling Stations



## oliver valvetek

### Subsea Valves

- Diver & ROV Operated Needle Valves
- Ball Valves Upto 15K
- Manual & Hydraulic Parallel Slide Gate Valves 3/8", 1/2", 3/4" and 1"



We Manufacture Valves for Global Energy Projects.  
**Find Your Local Supplier Call +44 (0)1565 632 636**

## oliver valves



### Reliability Under Pressure

+44 (0)1565 632 636 | sales@valves.co.uk  
 www.valves.co.uk

Oliver Valves Ltd Parkgate Industrial Estate,  
 Knutsford, Cheshire, WA16 8DX, United Kingdom

# Monitoring your environmental impact couldn't be easier!

With Quantum Outdoor from Cirrus Research.

Get instant access to your **noise, weather, air quality and ground vibration data** with Quantum Outdoor from Cirrus Research, our first fully integrated cloud-based comprehensive environmental monitoring system.

Quantum Outdoor can work in any environment, including providing long-term remote noise and environmental monitoring for the construction and demolition industry.

**Discover remote environmental monitoring:**  
[cirrusresearch.com/quantum-monitoring](http://cirrusresearch.com/quantum-monitoring)

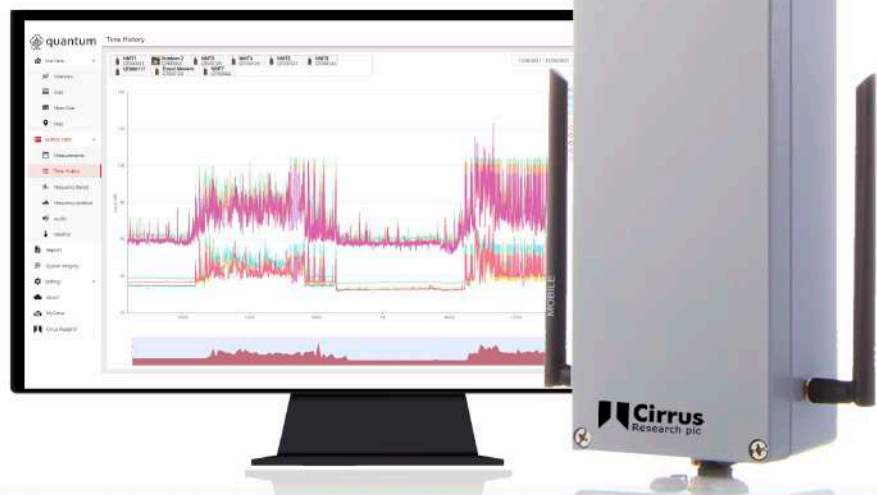

# SEMOTA:

## Sense, monitor, trigger, act

### Synthetic Variables

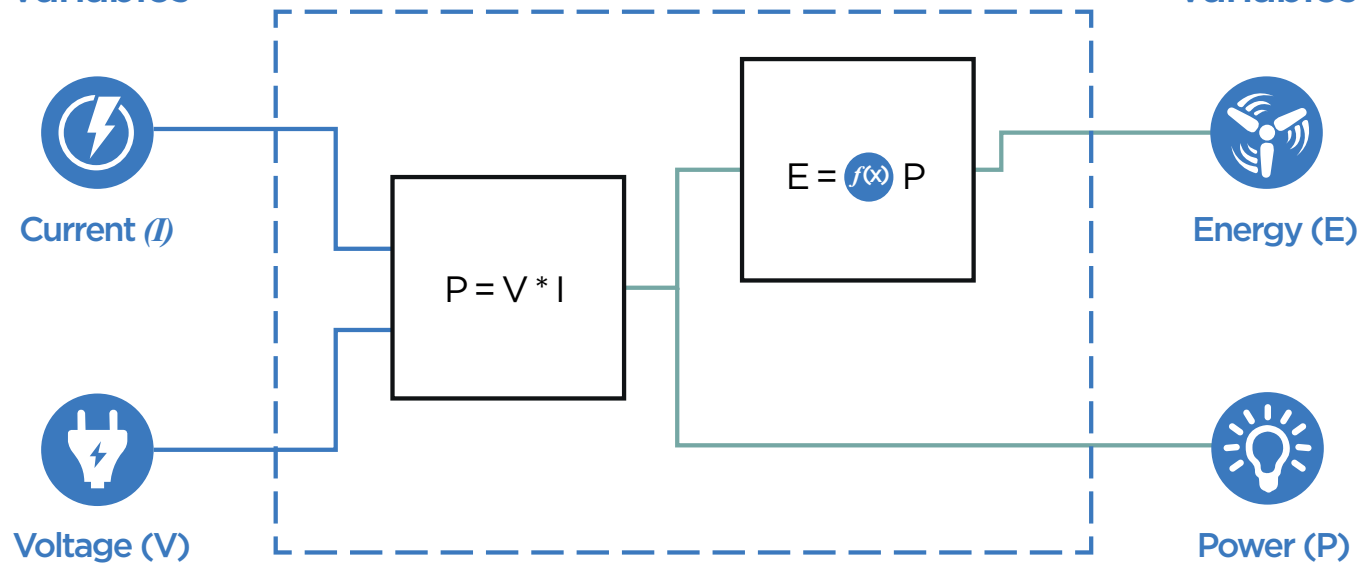

## The new remote monitoring solution from interface force

**S**EMOTA is a hardware and software solution with a web-based application that enables the remote monitoring of any load cell, force, torque or pressure sensor, using our Wi-Fi enabled hardware.

SEMOTA Continuous Remote Monitoring provides dynamic dashboard views of your events, analysis and device control. Information can be captured and stored for review and in depth analysis. Linkage to common messaging systems deliver live alerts for device management. Tailor and build applications to suit your needs and devices. Read more below, then complete the form and we'll arrange a demonstration.

### THREE YEARS STORAGE

Whether your data is needed every day or every few seconds, SEMOTA

is optimised to receive, compute, and return millions of data points across the globe.

### LIVE DASHBOARDS

Using SEMOTA point-and-click application development tools, create real-time dashboards to analyse data and control devices. Visualize data with SEMOTA stock graphs, charts, tables, indicators, maps, metrics, and control widgets or develop your own using the HTML canvas and your own code. Share your data through public links, or by embedding dashboards into custom web applications.

### EVENTS ENGINE

Add conditional and complex business logic to your hardware with triggered webhooks for M2M communication, and SMS, Email, Telegram, and Slack alerts to keep operators on-the-ball and informed.

### SYNTHETIC VARIABLES

Transform raw data into insights with Synthetic Variables that compute complex math formulas and statistical expressions.

### USER MANAGEMENT

With SEMOTA cloud software, you can build applications to best fit the operator's needs. SEMOTA administrators can configure permissions and restrictions to any end user or operator who interacts with dashboards, devices, and/or events. Need a user to be able to oversee multiple organisations? Not a problem. You can optionally add more users or organisations to your account and we can configure your users to best suit your application.

**T +44 (0)1344 776666**  
**info@interface.uk.com**  
**www.interface.uk.com**

# BUILDING UPDATE

ISSUE: 683 February | [www.solutionspublishing.co.uk](http://www.solutionspublishing.co.uk)



## STEEL BUILDING SOLUTIONS

+ SINGLE SKIN + COMPOSITE +  
ROLLER DOORS + WINDOWS +  
SKYLIGHTS + PERSONNEL DOORS  
+ INSTALLATION OPTIONS +



INDUSTRIAL

AGRICULTURAL

DOMESTIC

CASTLE STEEL BUILDINGS are focused on providing exceptional service as our first priority. We understand that most customers prefer a very personalised service, and so we are committed to ensuring that customers are completely satisfied with their purchase from start to finish.

GET A FREE ONLINE QUOTE AT  
[WWW.CASTLESTEELBUILDINGS.CO.UK](http://WWW.CASTLESTEELBUILDINGS.CO.UK)  
OR CONTACT US ON  
**01302 301402**  
[INFO@CASTLESTEELBUILDINGS.CO.UK](mailto:INFO@CASTLESTEELBUILDINGS.CO.UK)

## Quality bespoke steel buildings and structures

Doncaster-based Castle Steel Buildings Limited is the UK's number one supplier of cold formed steel buildings. From storage, workshops, private garages, agricultural buildings to commercial buildings, the Yorkshire company can design and supply for any applications.



Castle Steel Buildings work across commercial, industrial, leisure, equestrian and agricultural sectors to create the very best design solutions that last decades with little environmental impact.

Steel buildings are revered for robustness, flexibility and sustainability properties and can be moulded into many different shapes and sizes, making this the design product of choice for bespoke versatility. Steel is often chosen over wood in the industry as a material as it doesn't rot, warp or deteriorate with variables such as moisture or pests, allowing for structural longevity. Galvanisation and special paints also offer extra protection against corrosion and rust.

The team at Castle Steel Buildings can customise a building to suit your specific design purposes, from small storage sheds, to large commercial buildings. The designs can include the following options: insulated or non-insulated, roller shutter doors, personnel doors and many other features.

To find out more contact Castle Steel Buildings Limited on: 01302 301402 or visit the website for a free, no obligation quote at: [www.castlesteelbuildings.co.uk](http://www.castlesteelbuildings.co.uk)



Checkedsafe  
see them on....II-III



Independent Access Sales  
see them on....IV



Screwshop  
see them on....VII



Fennell Green & Bates  
see them on....XII



Fisher & Company  
see them on....XIII



DCON Safety  
see them on....XIV-XV



Discover the beauty of minimalist living with Avrame UK's eco-friendly kit homes. Our A-frame structures are designed for simplicity and sustainability, providing a harmonious blend of form and function. We offer a variety of customizable A-frame kit homes, including the Trio, Duo, and Solo series, to suit your unique needs.

Whether nestled in the countryside or perched on a city rooftop, Avrame homes offer a unique living experience, emphasizing natural light, open spaces, and a connection to the outdoors. With customization options, you can create a space that truly reflects your lifestyle.

Our homes are built with efficiency and sustainability in mind. They are energy-efficient, durable, and have a minimal environmental impact. With easy-to-follow instructions and high-quality materials, building your dream home has never been simpler.

At Avrame, exceptional customer service is our cornerstone. Our team of experts in planning, architecture, engineering, and construction works closely with you to ensure your home is tailored to your preferences. We are committed to transparency and responsiveness throughout the building process.

Choose Avrame UK for a beautiful, sustainable, and affordable home that stands the test of time. **Live smart, live sustainably, live Avrame!**

[WWW.AVRAME.CO.UK](http://WWW.AVRAME.CO.UK)



MODEL: TRIO 120  
LOCATION: UK



[www.facebook.com/solutionsuknews](http://www.facebook.com/solutionsuknews)



@Publishing\_2016

# Simple and inexpensive compliance solutions tailored to any industry.

CheckedSafe provide compliance services across commercial & plant hire businesses, utilities companies, and many other service sectors that are monitored for compliance.

## Vehicle Compliance

The vehicle compliance system for all fleets with paperless defect reporting and office portal.

- ✓ Driver's app
- ✓ GPS tags
- ✓ Back-office portal
- ✓ DVSA compliant

## Licence Checks Service

Conduct licence checks remotely ensuring your drivers have the correct credentials.

- ✓ Simple to use
- ✓ Pay as you go
- ✓ Remote use
- ✓ OCR technology

## GB Domestic Hours

Demonstrate your GB domestic hours compliance whenever needed.

- ✓ Ensure legal compliance
- ✓ Manager driver fatigue
- ✓ Improve productivity
- ✓ Real-time alerts

## Lone Worker

The smart way to protect lone workers with visibility of all your team members in the hub.

- ✓ SOS red alerts
- ✓ Welfare checks
- ✓ Worker down alerts
- ✓ Group notifications

## Dynamic Risk Assessment

Identify hazards, assess risk, take action, and review reports, on-site, and in real-time.

- ✓ Simple to use
- ✓ Pay-as-you-go
- ✓ Remote use enables
- ✓ OCR technology

Try free for 30 days  
Visit [checkedsafe.com](https://checkedsafe.com)





# How are YOU prioritising the safety of your commercial fleet?

Let's face it – how confident are you that your commercial drivers are truly prioritising safety on the roads? Can you be certain that daily walk-around checks are performed accurately? How do you know your drivers are actually getting out of their cabs to inspect their windscreens and tyres before ticking every box and going on their way? For many commercial fleets, the truth is that you don't.

It is well-documented that driving for work is one of the most dangerous things you can ask your employees to do. A staggering 33% of road deaths and 20% of serious injuries involve someone driving for work. So what are you doing about it?

## The reality of road safety in commercial fleets

Managing a fleet of commercial vehicles is no easy task. The logistical challenges are immense, and ensuring the safety of each driver is paramount. However, safety protocols can often become mere checkboxes in a long list of daily duties. When the pressure is on to meet delivery schedules and performance targets, it's easy for thorough inspections to fall by the wayside.

But this isn't just about meeting regulatory requirements or avoiding fines. The human cost is significant. When a driver skips a safety check, it could lead to severe consequences – an accident that could have been

prevented, injuries, or even fatalities. These incidents not only affect the driver and their family but can also have a profound impact on your business, from increased insurance premiums to the potential loss of contracts.

## The importance of thorough walk-around checks

Daily walk-around checks are a crucial part of ensuring vehicle safety. These inspections are designed to catch potential issues before they become serious problems. A cracked windscreen might seem like a minor issue, but it can obstruct the driver's view and become a major hazard. Worn tyres can lead to blowouts, especially at high speeds, putting the driver and others on the road at risk.

Ensuring that these checks are carried out properly is vital. This means making sure that your drivers are not just ticking boxes but are actually getting out of their cabs and performing the inspections thoroughly. However, manual checks can be inconsistent. Fatigue, complacency, or simple oversight can lead to missed steps, and without a robust system in place, these errors can go unnoticed until it's too late.

## Choosing CheckedSafe for safer roads

This is where CheckedSafe comes in. CheckedSafe is a comprehensive SaaS solution designed to ensure that your fleet's safety checks are carried out accurately and efficiently. With our system, you can digitise your inspection processes, making it easier for drivers to complete checks and for you to monitor compliance.

We provide a user-friendly app that guides drivers through each step of the inspection process, making sure that no item is overlooked. We do this by dating, timestamping and geolocating every time they press a button, so you can see if they have raced through the checks in two minutes or carried it out properly. The software also uses an accelerometer to make sure they're walking around the vehicle to do the checks, not just sitting in their cab.

Meanwhile, from your offices, you'll be able to monitor user activity, view comprehensive maintenance



reports in real-time, identify outstanding tasks and vehicle defects, and schedule services with our intuitive system. We also offer secure data storage and a clear end-to-end audit trail, so that you can protect your business in the event of investigations.

## Don't just tick boxes, commit to comprehensive safety

Don't wait for a serious incident to highlight the gaps in your safety protocols. Act proactively to mitigate risks and ensure that every journey your drivers make is a safe one. With CheckedSafe, you gain peace of mind knowing that your fleet is compliant, your drivers are protected, and your business is safeguarded against avoidable accidents and their associated costs. Prioritise safety, protect your drivers, and ensure the longevity of your business with CheckedSafe.

Take the first step towards a safer fleet today by visiting our website at: [www.checkedsafe.com](http://www.checkedsafe.com) or ring us on: 01282 908429.



# IAS: Success at APF 2024 and exclusive new Socage product

Independent Access Sales (IAS) sell market-leading manufactured platforms, such as Easylift Spider Platforms, SOGAGE Truck Mounting Platforms.

Based in Huntingdon, IAS has gone from a relative newcomer on the market to selling million-marked machines over the last two years. One the main reasons for the company's success is the focus on solid customer service. Founder Richard Martin has 35 years' previous sector experience across scaffolding, supervisory roles and surveying and understands the industry inside out.

With a focus on brand awareness, IAS brought its Easylift Spider Platforms and SOGAGE truck-mounted platforms to the APF Show from the 19th-21st September at Ragley Estate, Warwickshire. APF has been running since 1976 and is a respected dedicated biannual event for the whole forestry, woodland, arboriculture, firewood,



fencing, tree and timber sectors. It's the largest of its kind and attracted 23,000 visitors this year.

"APF 2024 was a huge success for us. We met lots of knowledgeable end-users, with a huge appetite for the latest machinery. As a biannual event, it had an extra buzz, with lots of strategic talk. We had lots of hot enquiries and sold a SOGAGE 24D double-articulated truck platform during the three-day event. This product has been precision-designed with safety in mind, with automatic stabilisation as standard. It can reach a working height of 23.60M and a lateral reach of 12,70M with a maximum load of 300kg: perfect for all tree surgery jobs. The SOGAGE 24D is set up to approach heights without risk of collision and with improved precision, which is ideal for manoeuvres like tree pruning." added Richard.

The Easylift Spider Platforms are also ideal for tree surgeons: with the range available from 13M up to 53M. The Easylift platforms give the owner

operator assurance and flexibility in business: simply put – more control over what to do in different environments. For tree surgeons, this allows operators the advantage of closing the Easylift Spider Platform down to less than 1M working width to take down a narrow footpath in a forest, to setting up on a hill to work at great height.

"We are delighted to report that from early next year, we will be supplying the SOGAGE 75M – which will be the largest SOGAGE access platform in the UK: a market-first. Contact us now for further information!"

**For more information or to speak to Richard Martin directly, please see the details below:**  
**M 07483 246878**  
**enquiries@iasales.co.uk**  
**www.iasales.co.uk**



SUPPLY AND SERVICE SPIDER PLATFORMS AND TRUCK MOUNTED PLATFORMS AND WILL HAVE THE PERFECT ACCESS SOLUTION FOR YOUR BUSINESS.

**FIND YOUR PERFECT PLATFORM**

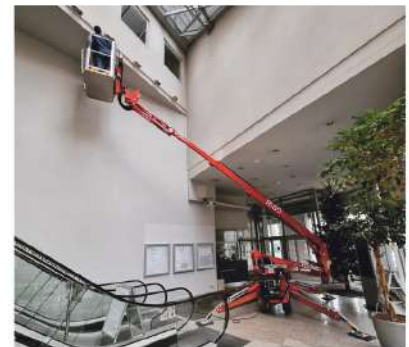

**GET IN TOUCH TODAY OR VISIT OUR WEBSITE TO VIEW OUR RANGE.**  
**T. 07483 246878 | E. ENQUIRIES@IASALES.CO.UK | W. WWW.IASALES.CO.UK**



# Support for Success

**Who we are:**

Here at Support for Success, we shine brightly in the realm of sustainable construction. We are pioneers in Green Skills Training and Consultancy.

In a world facing critical environmental challenges, our initiatives are not only commendable, but they are necessary for a healthy future. Our core mission is to provide meticulously crafted training courses that are both practical and theoretical. These courses, range between one to three days and include assessments along with multiple choice exams.

**Our courses:**

- Inspection Maintenance and Repair of External Wall Insulation
- Understanding Domestic Retrofit
- Floor Insulation
- Draft Proofing
- Loft Insulation
- Internal Wall Insulation
- External Wall Insulation

Accreditation from NOCN and endorsements from key industry bodies further validate the quality and effectiveness of our programs, offering participants the opportunity for industry-standard certification and recognition.

**How to take our courses:**

All our courses can be delivered on your premises or at one of our local venues. Please get in touch with us, to see what will suit you best.

**Learn from our experts:**

Here at Support for Success Ltd, we aren't just another training company; we're specialists in retrofit training and support, all delivered by experienced and qualified trainers. We're



passionate about training the existing workforce and awarding them with a recognised qualification, our courses are also a valuable tool for individual homeowners.

**Did you know that it is mandatory to have annual inspections on your External Wall Insulation?**

Our Inspection Maintenance and Repair course awards participants with a Level 3 Certificate in Competence issued by the awarding body, The NOCN. This course prevents any issues with the invalidation of warranties and guarantees through unchecked defects. This course is also CPD accredited. More details can be found on our website: [www.supportforsuccess.org](http://www.supportforsuccess.org)

The UK's growing emphasis on retrofitting homes presents a critical need. We address this need by

educating and upskilling both the current workforce and the next generation to come.

We have developed these courses in collaboration with industry experts and esteemed entities – such as, the National Insulation Association, the Insulated Render and Cladding Association, the Solid Wall Insulation Guarantee Agency, Exeter College, and SWIFIX Ltd. This collaborative approach ensures the credibility and relevance of our offerings, making us leaders in the field.

“Building a sustainable future – support for success in green skills training dedication to green skills training equips you with the tools to thrive in this ever-evolving industry.”

**T 01884 211542**  
**info@supportforsuccess.org**



# Support for Success

## Green Skills Training and Consultancy



**Our Vision**

At Support for Success, we're pioneers in green skills training and consultancy. In a world facing critical environmental challenges, our initiatives are not only commendable, but they're also necessary for a healthy future.

**What We Provide**

Support for Success Ltd is not just another training company. Support for Success are specialists in retrofit training and support. All delivered by experienced and qualified trainers. We are passionate about training the existing workforce and awarding them with a recognised qualification. Our courses are also a valuable tool for a individual homeowners.



01884 211542    INFO@SUPPORTFORSUCCESS.ORG    WWW.SUPPORTFORSUCCESS.ORG



**GOLD & WASSALL**  
QUALITY HINGES FOR OVER 200 YEARS

# MAKING HINGES SINCE 1790

## 100% UK MANUFACTURED

Gold & Wassall are the UK's No.1 manufacturer of hinges. We provide a fully comprehensive manufacturing service, which enables us to offer any hinge, for any application.

All our hinges are manufactured at our premises in Tamworth, UK.

We have a huge stock range, all of which are available for immediate dispatch.

**Continuous Hinges**

**Butt/Backflap Hinges**

**Lift-Off Hinges**

**Heavy Duty Hinges**

**Special Purpose Hinges**

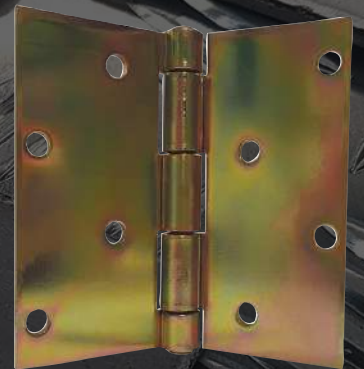

Please check our new website:  
**[www.goldwassallhinges.co.uk](http://www.goldwassallhinges.co.uk)**  
Email: **[sales@goldwassallhinges.co.uk](mailto:sales@goldwassallhinges.co.uk)**  
Telephone: **01827 63391**

# NE Fasteners celebrating 40 years 1985-2025

Screwshop, the home of our own brands – Turboqwik and Rhino Screws has evolved from its established sister company, NE Fasteners 10 years ago.

We are a family-owned company with over 30 years' experience, primarily specialising in screws fixings & fasteners for the DIY, hardware, building, joinery and furniture manufacturing sectors. Screwshop prides itself with offering expertise, competitive prices from local and internationally sourced standard and bespoke products.



Situated in Cradley Heath in the West Midlands, we are able to provide a wide range of finishes, including zinc, electro brass, black chrome, satin chrome, bronze and nickel, and packaging options, ensuring that many buyers consider us to be a key and valued supplier. Our extensive

product portfolio also includes builders' metalwork, brackets and ironmongery and silicone sealants and adhesives.

With friendly and experienced staff, our aim is to offer excellent service with our next day delivery service and give an opportunity for our customers to let us manage all fixings, fasteners and component requirements competitively.

**Screwshop has a trade counter which is open daily 8am-4.30pm. Have a look at our online shop: [www.screwshop.co.uk](http://www.screwshop.co.uk), or give us a call on: 0121 559 8866 with your enquiries and we will give you our best attention and prices at all times.**

## screwSHOP.co.uk

SCREWS FIXINGS FASTENERS BRACKETS FOAMS SEALANTS ADHESIVES AND MORE

THE HOME OF  
**TURBOQWIK**

THE PRECISION MULTIPURPOSE  
PREMIUM WOODSCREW

**RHINO  
SCREWS**



**Ironmongery & Furniture Fixings**

**SHOP NOW**



**Power Tool Accessories**

**SHOP NOW**



**Woodscrews & Screws for Metal**

**SHOP NOW**



**Drylining, Window & Outdoor Screws**

**SHOP NOW**

SCAN TO  
VISIT US



LOW PRICES UK NEXT DAY DELIVERY  
**THE EXPERTS CHOICE SINCE 1985**

# Elite event crewing services

Olympus Crew offers a comprehensive range of event crewing services, distinguished by its highly trained and versatile team. With expertise spanning from tools and staging to AV and lighting, the crew is prepared to handle a range of diverse tasks efficiently.

Founded in 2018, Olympus Crew has rapidly established itself as a versatile and reliable partner in the event industry. Over the past six years, they have successfully managed a wide array of events, including festivals, corporate gatherings, live shows, and sporting events. With seasoned

crew chiefs at the helm, Olympus Crew ensures smooth operations, effective client communication, and proficient management of large on-site teams. Its dedication to excellence makes them a standout choice for event execution.

Olympus Crew have the ability to travel all over the UK and even overseas when required. The team is made up of diverse skillsets including carpentry, audio visual, physical and mental strength, as well as forklift and IPAF operators.

The crew will be with you from the start to the end of each project. Whether that be picking items from a warehouse, building and painting sets in a workshop or loading



and unloading trucks, Olympus Crew offer as much off-site as they do on.

If you're looking for an elite crew that is professional in its execution with a hardworking attitude, get in touch today and a member of the team will be in touch within 48 hours.

**M 07904 903452**  
**info@olympuscrew.co.uk**  
**www.olympuscrew.co.uk**



## Event Crew in Leeds & in London, UK

**We are a crewing company, for the clients, and for the crew.  
We ensure the best services for you**

Olympus Crew set up in early 2018 has developed into offering event solutions with crew, technicians and carpenters nationwide. Staffing jobs and events predominantly in the north of the UK, Olympus Crew has now spread across the UK and the globe working on some of the worlds most prestigious events.

### Event team Leeds and London

Whether it's a big or small event, International or Local, Olympus Crew have you covered. With crew operational in Leeds and London, with the ability to travel far and wide, we are a convenient and proficient option for you to use for your crewing needs. As well as the UK, we've sent crew to Europe, Asia, Australia, North and South America, so wherever we're needed we'll be there for you.

Here at Olympus Crew, we have a dedicated team of hardworking professionals who form the Olympus Crew family. To date, we have over 80 crew members which increases daily.

Please visit [www.olympuscrew.co.uk](http://www.olympuscrew.co.uk)

Contact **079 049 03452** or email [info@olympuscrew.co.uk](mailto:info@olympuscrew.co.uk)



# One-stop-shop for indoor and outdoor sports and leisure spaces

The UK has seen an explosion in indoor recreational spaces, from trampoline parks, Ninja Warrior courses to soft play centres.

The first indoor Trampoline Parks opened in 2014 and over the last ten years, over 150 parks have opened. From corporate days out, to children's parties and clubs, trampoline parks are a growing industry.

Ninja Warrior Courses have likewise sprung up in major cities across the country, all inspired by the ITV hit programme Ninja Warrior UK. From Leicester to Liverpool, children and teenagers of all ages put their Ninja skills to the test in a series of physical obstacle courses.

Soft Play Centres hardly need an introduction, as most aunts, grandparents, and parents will have taken their child or younger relative to one at some point. Come rain or shine, all year round, soft play centres provide hours of safe, sociable fun for babies,



toddlers and children. Designed for children to let off steam, the integrated slides, ball pits and play areas are perfect for weekly meet ups and children's parties.

For companies looking to increase franchises and open new centres, it's always good to use manufacturers renowned for professionalism, expertise and excellent customer service. The Playcraft Group fits the bill with 40 years' children's play industry and 25 years' play centre attraction industry experience. Based in South Wales, the company offers a one-stop-shop for design, manufacturing, installing and maintaining trampoline parks, climbing walls, Ninja Warrior courses, adventure playgrounds and much more.

"We offer bespoke installations across the indoor and outdoor sports and leisure sector, as one of the few one-stop-shops in the industry. Our previous high-profile clients have included Disney, Land Rover and Cartoon Network and we work with farm parks, theme and holiday parks, schools, the FEC sector and more. We know the business inside out and we're happy to offer free 360° advice from business plans and models, to planning application support, insurance to franchising advice. From Jungle or Space themed soft play, climbing wall in a new upcoming urban space, to an exciting Ninja Warrior Course, we can do it all.

Currently we are working on a wheelchair-friendly, soft play section for a local soft play centre. We are adapting our soft play materials to incorporate the width of an electric or manual wheelchair. The end result will be an inclusive space for children in



wheelchairs. More and more soft play centres are adding sensory spaces (lights, textures etc) to support neurodiverse children, to increase inclusivity for children and their families," explains Mike Broadfield: founder, coach and consultant.

**To start your indoor leisure franchise journey today, contact Mike on the details below:**  
**T +44 (0)1792 422818**  
**hello@playcraftgroup.com**  
**https://softplay-manufacturer.com**



**CHOOSE US FOR 'DIRECT' SUPPLIES**

## Multiple Facilities

- Trampoline Parks
- Soft Play Areas
- Climbing Walls
- Ninja Warrior Courses
- Adventure Playgrounds

## All In-House

One of the only companies who:

- Design
- Manufacture
- Install
- Finance

## FREE 360° ADVICE

We help ensure your success with:

- Business Plan & Model
- Planning Application
- Success
- Financials & Insurances
- Franchising

Find out more at [softplay-manufacturer.com](https://softplay-manufacturer.com)  
**Tel +44 (0)1792 422818 | [hello@playcraftgroup.com](mailto:hello@playcraftgroup.com)**



# Warwick Buildings Ltd wins Award of Excellence for 2024

**W**arwick Buildings Ltd is a leading local supplier of high quality timber buildings, specialising in garden offices, modern garden rooms, and wooden garages. With a focus on quality craftsmanship and a commitment to using sustainable materials, Warwick Buildings is a trusted name in the industry, providing customers with versatile, aesthetically pleasing structures enhancing their outdoor spaces. Founded in 1988, at the heart of Warwick Buildings' success is its customer-centric approach. The company prides itself on delivering a personalised service, assisting customers from the initial design phase to the final installation.

E2 Media have recently unveiled their highly anticipated 2024 Awards of Excellence. Warwick Buildings Ltd, have secured the prestigious award for the second consecutive year. Their



exceptional dedication to providing unparalleled customer service has set them apart.

Warwick Buildings' outdoor buildings are designed to meet the growing demand for functional workspaces within the tranquillity of your home. These structures are crafted with precision and attention to detail, utilising high-quality timber. Whether for remote professionals or those looking for traditional office spaces, these garden offices are a perfect solution.

**For more information, please visit: [www.warwickbuildings.co.uk](http://www.warwickbuildings.co.uk)**

# Bluerun Ltd once again achieves excellence in the workplace

**U**pon reopening its doors in May 2020 after the COVID-19 pandemic, Bluerun Ltd has gone from strength to strength with its trusted brand now being known as one of the best in the joinery industry that has recently attracted big name brands turned clients, Starbucks and Waitrose.



Of course, the company has the capabilities to manufacture most things from timber, hardwood, softwood, panels and sheet material. Some common items Bluerun Ltd manufacture for the domestic building market

include windows, doors (exterior and interior), bi-folding doors, staircases, bespoke storage units and wardrobes, all of which come with the option of being sprayed in primer or to a finish.

Since 2022, the company has continued to strengthen in terms of revenue and new business. It has managed to maintain a strong conversion rate despite the current economic crisis and has found that enquiries for larger jobs as opposed to 'single window' types of jobs has been more popular especially from domestic clients.

Based in Wimbish, near Saffron Walden in Essex, Bluerun manufactures quality, bespoke joinery items for the commercial market from door and window packers to shopfronts, reception desks, mainframes, pub doors, and years ago, even made a trebuchet for Stansted Mounfitchet castle!

If you're looking for items made from both hard and softwood or even veneered and painted panels, Bluerun can reproduce an array of items including replacement sashes, where it can manufacture a brand new one on a like for like basis, so the mouldings will match. Similarly, if a domestic client has found an image of a door that they would like reproduced, Bluerun can usually do that. Recently the company has started using a glass supplier that supplies them with stained glass effect units, complete with leading that has been aged and soldered.

**T 01799 599995**  
**[dee@bluerunltd.co.uk](mailto:dee@bluerunltd.co.uk)**  
**[www.bluerunltd.co.uk](http://www.bluerunltd.co.uk)**



**Bluerun Limited**

*quality bespoke joinery since 1991*

**QUALITY, CUSTOM  
MADE JOINERY**



**Bluerun Ltd have been manufacturing top quality, purpose made joinery for the domestic and commercial markets for over 30 years.**



Please visit our website: **[www.bluerunltd.co.uk](http://www.bluerunltd.co.uk)**

Tel: **01799 599995** | Email: **[dee@bluerunltd.co.uk](mailto:dee@bluerunltd.co.uk)** f **[bluerunltd](https://www.facebook.com/bluerunltd)** @ **[bluerun\\_joinery](https://www.instagram.com/bluerun_joinery)**



# LE TONKINOIS VARNISH



LE TONKINOIS VARNISH IS A NATURAL OIL BASED YACHT VARNISH, USING A CHINESE FORMULA DATING BACK TWO OR THREE CENTURIES. AND WHAT A FORMULA!

IT REMOVES YOUR BRUSH-MARKS, BRINGS OUT THE NATURAL BEAUTY OF THE TIMBER, DOESN'T CRACK OR FLAKE OFF, AND IS PERMANENT, SIMPLY ADD A FURTHER COAT EVERY FEW YEARS.

Click here  
**ebay**

Please visit [www.letonkinoisvarnish.co.uk](http://www.letonkinoisvarnish.co.uk)  
Telephone 01628 629892 or email [mail@letonkinoisvarnish.uk](mailto:mail@letonkinoisvarnish.uk)



## Pandor

### BESPOKE DOOR AND PANEL MANUFACTURERS

FIRE DOORS | ACOUSTIC DOORS | PANELLING | DOOR FRAMES

#### THREE KEY VALUES

SUPERLATIVE QUALITY | SHORTEST DELIVERY | ATTENTION TO DETAIL

OFFERING SERVICE LIKE NO OTHER

EXCELLING IN ACHIEVING FAST LEAD TIMES  
FOR BESPOKE FIRE DOOR SETS

QUALITY AND SERVICE WITH A SMILE

PROUD MEMBERS OF THE BM TRADA Q-MARK SCHEME  
FOR FIRE DOORS YOU CAN DEPEND ON

UNIT F2/F3 | LONDON ROAD TRADING ESTATE  
SITTINGBOURNE | KENT | ME10 1SX

CALL: 0208 279 7611 | 07909 530 007

EMAIL: MIKE@PANDOR.LTD | PANDORLTD@HOTMAIL.COM

## Surveyors



### Fennell, Green & Bates

MINING ENGINEERS, SURVEYORS & ENVIRONMENTAL CONSULTANTS

Fennell Green & Bates Chartered Surveyors is a 150 years old practice based in Wakefield. At FGB, we specialise in building condition surveys, house structural surveys, project management, town & country planning, coal mining risk assessments, site investigation and remediation of brownfield land.

Fennell Green and Bates have been involved in over 1,740 projects over the past 22 years dealing with contaminated land, ground stability issues, phase 1 contaminated desk top studies, phase 2 site investigation projects, coal mining risk assessments and soil sampling for housing, commercial and industrial developments in north of England and the Midlands. Our practice also acts as mineral advisors to several building materials companies and that work has taken our surveyors all over the UK and to Ireland, Europe, Russia, South Africa and Australia to work on a wide range of projects.

At present we are managing the remediation of a glass works tip on behalf of a client for the site to be used as housing after the materials on site have been processed and re-engineered on-site for the development platform. We have recently completed the verification of the works for a medium sized housing development in Yorkshire in a former quarry that has been backfilled with engineered fill from site.

Our team is experienced in all types of site engineering and soil management that includes materials testing that can save costs due to the re-use of these soils and a reduction in muck away.



**Fennell Green & Bates**

Old Joiner's Shop, 59 Oakenshaw Lane  
Walton, Wakefield, West Yorkshire WF2 6NJ

**Tel:** 01924 255666

**Mob:** 07739 256461

**Email:** fennellgreenandbates@gmail.com

**Website:** www.charteredurveyorswakefield.co.uk

## Feeder Pillars

We manufacture and supply a huge range of Feeder Pillars to suit every purpose in galvanised or stainless steel and GRP, Shell only or pre-wired



For every type of power distribution, EV Charging, MRI for Hospitals, Sports & Leisure, Parks & Gardens, Events & Markets, Multi-Service & Multi-User



We keep a wide range of quality Feeder Pillars in stock. Bespoke and made to order delivered from 2-3 weeks!

## Belisha & Refuge Beacons

### AmberGLO8

8W LED Beacon with amber globe and aluminium gallery with 3No. Reflective white bands. Reliable and long lasting



### OlympiadIPB

30W total LED Beacon High Visibility with illuminated and reflective white banding



### Lodestar

LED Refuge Beacon 12W with Pearl Globe and Traffic Grey Gallery



### Sentinel26

Refuge upgrade 26W total High Visibility LED Beacon with 2No. Illuminated reflective white bands. Suitable for retro fit or new install.



Full range in stock - Complete Beacons and accessories - Courtesy Shields, LED Crossing Spotlights, Bracket Arms and retrofit spares such as Reflective White Bands etc.



Contact our Sales Team now on **0333 666 2122** or email **info@fisherandcompany.co.uk**

Visit **www.fisherandcompany.co.uk** to view our range of products

1-4 Cary Court,  
Somerton Business  
Park, Somerton,  
Somerset TA11 6SB



## Water Monitoring & Treatment



# THE NEUTRALIZER

Mobile CO<sub>2</sub> pH Balancing for the Construction Industry

Fast, Continuous In-line Process  
Up to 50m<sup>3</sup>/hr Flow Rate  
Remote Cloud Based IOT Monitoring  
Worldwide Shipping Available

+44 (0)1422 363463 connect with us on LinkedIn [www.smartstormgroup.com](http://www.smartstormgroup.com) [Sales@smartstormgroup.com](mailto:Sales@smartstormgroup.com)



# Make your project possible

**D**CON Safety Consultants Limited offers leading health and safety consultancy and construction statute advice services. The company prioritises and specialises in the highest levels of informed and intelligent advice, senior project resource allocation and compliance assurance. Informed by industry expertise, DCON Safety Consultants Limited knows that every project has potential risks, no matter what its potential benefits, so its team of highly experienced construction professionals helps to ensure clients' statutory conformity.

Upon gaining understanding of the specific needs, goals and desires of each client and their project, DCON Safety Consultants Limited is dedicated to implementing a design and construction management plan that will meet or exceed these requirements. And, DCON Safety Consultants Limited ensures that there is honesty, integrity, trust and professionalism underpinning every project.

Moreover, the company's services are centred on three delivery principles:

- **Maximising Quality:** The company implements proven health, safety and wellbeing strategies to help clients achieve high quality and cost-effective work commensurate with the design of their projects.
- **Minimising Risk:** The company effectively manages design and delivery risk on projects to match each client's desired risk level profile.
- **Managing Compliance:** The company relies on its extensive background working on a wide variety of projects to assist clients in developing, monitoring and maintaining compliance performance.

This excellent service would not be possible without the leadership of Diarmuid Condon, a construction industry leader who brings unique perspectives to encourage, support and mentor the abilities of his colleagues. As a construction professional with a surveying background and experience spanning two decades, Diarmuid is emblematic of DCON Safety Consultants Limited's commitment to providing outstanding services to clients.

Diarmuid has contributed his invaluable expertise to over 400 projects over 20 years, with a client list including public sector departments, corporate owners, real estate developers, main contractors, design professionals and infrastructural bodies. With this incredible portfolio, Diarmuid is helping DCON Safety Consultants Limited to become a leader in health and safety consultancy across the construction industry.

Key to DCON Safety Consultants Limited's services is working as a Project Supervisor for the Design Process and CDM Advisor in various



sectors across the Irish construction market. No project is too simple or too complex for the company's construction safety consultants, all of whom are construction professionals with an average of 20 years' experience in the built environment. The ability to maximise this knowledge and skillset means DCON Safety Consultants Limited can generate distinctive and innovative ideas from traditional PSDP service inputs and outputs.

DCON Safety Consultants Limited also provides its main contractor clients with intelligent, practical, and reasonable physical site safety advice to support compliance and good practice adherence. Behavioural safety outcomes inform how the company approaches each solution with the contractor and their supply chain, identifying opportunities for improvement.

To complement this, DCON Safety Consultants Limited can also help with clients' health and safety strategy. Its holistic and integrated approach can help unlock substantial benefits for clients by providing a structured, objective and SMART framework for full optimisation through the

creation of an environment that embraces health, safety and wellbeing.

This means DCON Safety Consultants Limited helps clients to improve their health, safety and environmental performance; enhance staff satisfaction thanks to improved performance; improve risk management and corporate governance with a clear audit trail; gain confidence from long-term planning, better sustainability and performance; and improve overall corporate reputation, including greater staff satisfaction and a more efficient procurement and supply chain.

If you are interested in finding out more information on DCON Safety Consultants Limited's full range of excellent services, head to the website or get in touch directly using the contact details below.

**T +353 (0)1 611 1556**  
[diarmuid.condon@dconsafety.com](mailto:diarmuid.condon@dconsafety.com)  
[www.dconsafety.com](http://www.dconsafety.com)





# Leaders in Built Environmental Safety and Health and Wellbeing Consultancy



**Consulting on various aspects of project design, constructability and operational lifecycle matters for local and global commercial clients.**

DCON Safety Consultants is committed to understanding the specific needs, goals, and desires of each individual client and project. Upon gaining this special understanding, we commit ourselves to the implementation of a design and construction management plan that will meet or exceed these requirements. Our foundation for each project is honesty, integrity, trust, and professionalism.



## OUR SERVICES

- DESIGN SUPERVISOR
- PLANNING COMPLIANCE
- CONSTRUCTION HEALTH & SAFETY
- HEALTH & SAFETY STRATEGY
- EXPERT WITNESS

Please visit: [www.dconsafety.com](http://www.dconsafety.com)

Email [info@dconsafety.com](mailto:info@dconsafety.com) • Phone +353 (0)1 611 1556

DCON Safety Consultants, Suite 5, Fitzwilliam Square East, Dublin 2

## Pioneering sustainability with Recycled Plastic Innovations

In this issue of Building Update, we are proud to spotlight Kedel as our top recommendation for eco-friendly plastic products in 2025.

This recommendation comes off the back of a fantastic year for Kedel. 2024 saw the company win double awards in the Feefo Trusted Service Awards 2024 as well as receive the Exceptional Service and Gold Trusted Service Awards 2024. These awards epitomise their exceptional customer experience across the board, which has been at the heart of Kedel operations since inception.

Kedel is a market-leading manufacturer and distributor of recycled plastic products, outdoor and park furniture. With a focus on sustainability, Kedel has been a front-runner in the industry since winning the 'Best Recycled Plastic Product' at the National Recycling Awards back in 2015.

Over the years, the family business has expanded, with a product range now serving a wide customer

base including local Government, housing associations, education, construction and domestic sectors.

The three founders are brothers: Kieran, Dermot and Lewis Walch, whose endeavour to bring sustainable products to the foreground have made Kedel products the 'industry's products of choice.'

"We manufacture plastic wood made from waste polystyrene, and we are also suppliers of many other types of recycled plastic profiles from other manufacturers. We stock tongue and groove boards, plastic sheet materials, decking, cladding, ground reinforcement and drainage grids, fencing and gates. In addition, we make a wide range of outdoor furniture often combining different types of recycled plastic into one product. These products include benches, tables, picnic tables, and notice boards just to name just a few. We also offer design services and have a large flatbed CNC (computer numerical controlled) machine for cutting and shaping to the CAD design parameters supplied by our customers,



or created for them by our in-house design team," explained Lewis.

Using recycled plastic offers a dual advantage: it significantly reduces the carbon footprint while delivering substantial returns for businesses. These products are rot-proof and require no ownership costs, maintenance, labour, materials, or replacement expenses, making them a cost-effective and sustainable choice.

Take Kedel's plastic fencing panels for example, which are an ideal solution for end customers, including housing associations. Unlike traditional wooden panels, they eliminate the need for frequent replacements. The entire sustainable range withstands frost without cracking and remains intact even under heavy rain, avoiding splintering or damage. Additionally, Kedel's benches and picnic tables are perfect for educational institutions, providing durable outdoor furniture without the burden of high maintenance costs.

To find out more about the full product range, click here: [www.kedel.co.uk](http://www.kedel.co.uk)



## The Zero Maintenance Alternative to Wood

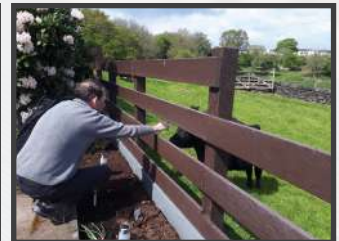

### Recycled Plastic

- 100% recycled and recyclable
- Impervious to fungi, algae, insects
- Never rots, splinters or cracks
- Graffiti resistant
- UV Protected
- Eco-friendly and low carbon
- 100% maintenance free
- Lasts a lifetime



Please contact us on 01282 861325  
sales@kedel.co.uk | [www.kedel.co.uk](http://www.kedel.co.uk)



# Dolwin & Gray

Established 1969



**Professional, fully trained & qualified Tree Surgeons & Landscapers in & around London & the South East**

Hedge, Copse & Woodland planting  
(Transplants to semi-mature)

Cultivation & Seeding Paddocks etc Turfing

All aspects of Tree Work, Surveys and Reports to BS5837:2012 Trees in Relation to Design, demolition and construction – Recommendations

Tel: **01892 853232** • Fax: **01892 853434**

Email: [enquiries@dolwinandgray.co.uk](mailto:enquiries@dolwinandgray.co.uk)  
[www.dolwinandgray.co.uk](http://www.dolwinandgray.co.uk)



## Landscaping and tree surgery

With a team of professional, fully trained and qualified tree surgeons and landscapers, Dolwin & Gray offer a range of tree servicing including Pruning, cleaning, reduction & reshaping, crown lifting and sectional dismantling of trees both large and small as well as the grinding of stumps. Servicing London and the South East, the company is a well-established business with over 44 years of experience.



Dolwin & Gray was first set up as a Forestry company by Mr John Dolwin and Mr Don Gray back in 1969. Today it has progressed to being a highly successful Landscaping & Tree Surgery business and is owned and run by partners Colin Goss and Frin Noakes.

Both domestic and commercial work is undertaken by the company and they also offer tree reports & surveys to BS5837:2012 Trees in

relation to design, demolition and construction recommendations. The team can assist with applications for work to be carried out under Tree Preservation Orders and conservation areas with the Local Authorities. They also carry Public Liability Insurance of 10 million for your peace of mind.

**Contact**  
**T +44 (0)1892 853232**  
[enquiries@dolwinandgray.co.uk](mailto:enquiries@dolwinandgray.co.uk)  
[www.dolwinandgray.co.uk](http://www.dolwinandgray.co.uk)

## Storage Space

**WBS** WALLBED SYSTEMS  
*Let's build a Wallbed together*

**LEADING FOLDAWAY BED SUPPLIERS**



Wide Range



Highest Quality



Competitive Prices

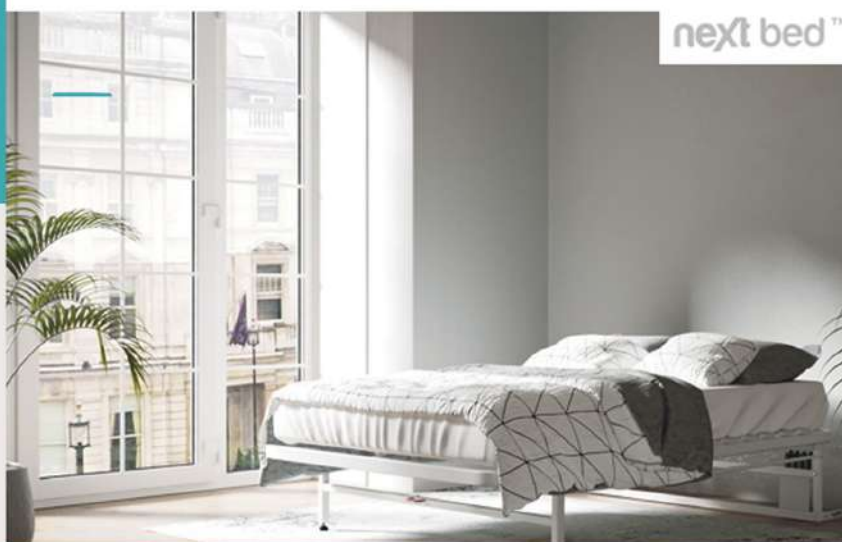

Wallbed Systems designs, develops, manufactures, and distributes a wide range of wall bed systems to 27 countries around the world.

**Wallbed Systems Ltd.**

[www.wallbedsystems.co.uk](http://www.wallbedsystems.co.uk) | [Jeremy.Waller@wallbedsystems.co.uk](mailto:Jeremy.Waller@wallbedsystems.co.uk)  
+44 (0)208 704 5796 | +44 (0)7780 66 1958

## Hinges



**GOLD & WASSALL**  
EST. 1790

Gold & Wassall have been manufacturing hinges for over two centuries, so it's safe to say we know what we're doing.

Our team of experts can design and manufacture almost any hinge, for any application.

T 01827 63391  
sales@goldwassalhinges.co.uk  
www.goldwassalhinges.co.uk

## Project Management Software



**elevate**<sup>TM</sup>  
Construction Made Easy

Elevate software can provide real-time updates, directing everyone on actions and this results in the team, prioritising their time and becoming more productive.

www.elevate-software.co.uk

## Interior & Exterior Furniture



**BESPOKE CRETE**

BespokeCrete creates custom and bespoke furniture, outdoor kitchens, kitchen worktops, waterfall islands, patio sets, indoor table & bench sets, coffee tables, baths, sinks and so much more – that is fully waterproof, heat, stain and scratch resistant.

T 0800 061 4157  
info@bespokecrete.com  
www.bespokecrete.com

## Deephole Drilling



**UNISIG**  
DEEP HOLE DRILLING SYSTEMS

Our industry-leading customers around the world rely on UNISIG® deep hole drilling technologies for powerful, productive solutions and value. We engineer our machines to handle a complete range of applications, and support them with our high level of expertise and service.

www.unisig.com

## Safety Consultancy



**DCON**  
SAFETY CONSULTANTS

DCON Safety Consultants is committed to understanding the specific needs, goals, and desires of each individual client and project.

T +353 (0)1 611 1556  
info@dconsafety.com  
dconsafety.com

## Sign Plaques & Architectural Castings



**LEANDER**  
ARCHITECTURAL

Manufacturers and designers of high quality fingerpost signs, bandstands, bespoke canopies, Porte-cochère, blue plaques, noticeboards, cast signage, memorial plaques, street furniture, gazebos and much more.

T 01298 814941  
www.leanderuk.com

## Portable Buildings



**ModConCabins**  
Manufacturer of Modular, Containers & Cabins

ModCon Cabins provides modern, affordable and bespoke modular and portable buildings for a multitude of situations, each one carefully crafted from new and used shipping containers.

T 0333 404 8822  
modconcabins.co.uk

## Eco-Friendly Plastic Products



**KEDEL** TRADE  
ECO-FRIENDLY PLASTIC PRODUCTS

Kedel Limited is a family business, founded on ethical and ecologically sound principles.

We created our business to showcase the very best recycled plastic products, putting green, sustainable living at the heart of all our company decisions.

T 01282 861325  
www.kedel.co.uk



## Compliance Solutions



CheckedSafe was developed to provide simple and inexpensive compliance solutions that could be tailored to any industry.

**T 01282 908429**  
**info@checkedsafe.com**  
**www.checkedsafe.com**

## Timber



The Company was founded in 1883 by Louis Vandecasteele. In those days, wagon making was the main commercial activity. Desiré Vandecasteele, son of the founder, then added a small sawmill.

**Contact**  
**T +32 56 43 33 00**  
**vandecasteele.be/en**

## Machinery



With 35 years of experience in the access industry, we will find the platform most suited for your needs and supply at the best price achievable.

Independent Access Sales offer a complete service management facility throughout the UK.

**T 07483 246878**  
**enquiries@iasales.co.uk**  
**iasales.co.uk**



## Landscaping Machinery



Eco Clipper offers large electric-powered mowers that help field managers minimise mowing costs for sports fields. Users report high productivity gains and appreciate low maintenance requirements, quiet operation and the ability to schedule mowing even under less favourable mowing conditions, such as early morning dew and wet autumn.

**T +31 (0)6 46 75 35 60**  
**www.ecoclipper.com**



## Engineering & Consultancy



Bartels & Vedder is an engineering firm, specialised in floating and flood proof buildings and structures.

**T +31 (0)6 422 398 53**  
**www.bartelsvedder.nl**

## Waterproofing



TuffStuff® is the UK's premium designer, manufacturer and supplier of heavy-duty GRP waterproof flat roofing systems.

**T 01977 680250**  
**orders@tuffwaterproofing.co.uk**  
**www.tuffstuff.co.uk**

## Fixings



Our Award Winning Solutions are one of the most cost-effective solutions to enable the fitting of external furniture through external wall insulation and rain screen cladding, with the added benefit of being designed specifically for the job.

**T 01884 211540**  
**info@swifix.co.uk**  
**www.swifix.co.uk**



## Storage



Wallbed Systems offers a large range of wallbed hardware designs. We produce many different styles of wallbeds and ship all over the world.

**Contact Jeremy Waller,**  
**T +44 (0)208 704 5796**  
**jeremy.waller@**  
**wallbedsystems.co.uk**  
**www.wallbedsystems.co.uk**



Check out our most compact line of electric large-area mowers – the front or rear-mounted Eco Clipper, with a 343cm mowing width for compact tractors.

# **eco clipper**®



- Low Noise
- Fuel Efficient
- High-Quality Finish
- Performs Well In Wet Grass
- 170cm Transport Width



[www.ecoclipper.com](http://www.ecoclipper.com)



# *Continuous Remote Monitoring*



**Three years time storage**  
3 years rolling data retention



**Live dashboards**  
Create real-time dashboards  
to analyze data and control devices



**Events engine**  
Keep operators on-the-ball  
and informed



**Synthetic Variables**  
Transform raw data into insights



**User management**  
Build applications to best fit  
the operator's needs

---

## **Interface Force Measurements Ltd**

Ground Floor, Unit 19, Duke's Ride, Wellington Business Park  
Crowthorne, Berkshire RG45 6LS

Tel: +44 (0)1344 776666 | Email: [info@interface.uk.com](mailto:info@interface.uk.com) | [www.interface.uk.com](http://www.interface.uk.com)

## CML readies itself for a surge of new market opportunities

CML Innovative Technologies (CML) is the leading manufacturer of LED signal lamps for all industrial applications and has been working with light since 1931. As a market leader in its field, CML was one of the first companies to introduce LED lamps and now has one of the broadest ranges of miniature lighting products in the world. "In 2004, the company became CML and continued to grow, establishing its international pedigree with two factories in Guangzhou, China, and Sibiu, Romania. While CML remains in Bury St Edmunds, the group was acquired by Spain's Grupo Antolin, which employs 28,000 people globally," stated Roger Neal, Commercial Manager.



From lamps for signalisation, panel mount indicators, LEDs, LED displays, medical lamps, and aviation lamps, CML provide light to an abundance of markets and pride itself on the ability to be as flexible and adaptable as possible in the manufacture of their own branded products to meet customer specifications and demand.

"CML in the UK focuses on specialist applications mainly manufacturing lighting solutions for automotive, aviation and general industries. We manufacture a standard range of products and customer-specific solutions from customer concept to production, including in-house design. Our portfolio runs to thousands of miniature lighting options in size, function, colour, finishes and voltages," said Roger.

CML is continually developing its own product range and has recently witnessed positive movements from customers seeking more product value. Some competitors fall short as they only provide a face value market product however, CML offers further manufacturing capabilities such as the add-on of cables and connectors to a product, which carries weighted value. The ability to meet customer specific requirements has attracted much attention in the industry as the manufacturing processes available from CML dramatically reduce production time through its made to order service.

"Nothing is impossible for us, we produce to customer demand working with customers. We have done work for individual airlines and collaborated



with their design division to manufacture LED replacements for incandescent lamps. There is a cockpit lamp, which we have produced for years, and there can be up to 1,200 different pieces per aircraft of that particular type. Our possibilities are endless," remarked Roger.

You will find CML products all over the world, from medical applications to gaming industries, by having full control of the entire value chain enables CML to be flexible with our clients' requirements. Since COVID-19, 50% of the business has come from industrial sectors. "Automotive sales have improved in the last year and the industrial side has witnessed significant growth. The pandemic has only made us stronger as a company, and as a result, our flexibility has generated an upturn in demand and helped create new business opportunities," said Roger.

For more information, please see below:  
T 01284 714700  
uksales@cml-it.com  
www.cml-it.com/en



### High Quality Panel Mount Indicators

CML IT continues to be the number one supplier of panel mount indicators, LED lamp replacements and LED tower lamp solutions.

PMI highlights include:

- Plastic and metal bezels with a wide range of options in stock.
- IP40 and IP67 ratings.
- Development of custom solutions.
- UK manufacturing facilities.



Contact our Customer Services department to discuss your requirements today.



CML Innovative Technologies Ltd,  
69/70 Eastern Way, Bury St Edmunds,  
Suffolk, IP32 7AB, United Kingdom  
Tel: +44 (0)1284 714700  
email: uksales@cml-it.com

Visit our website at: [www.cml-it.com](http://www.cml-it.com)

# DO YOU KNOW THAT BIOPHARMA GROUP OFFERS *Ultra* PRODUCTION FREEZE DRYERS

WITH CUSTOMISABLE CONFIGURATIONS,  
SUITABLE FOR CLEANROOMS & ASEPTIC GMP FACILITIES?



Used extensively in  
ISO 13485 environments,  
our range of freeze dryers from  
**ATS LIFE SCIENCES SCIENTIFIC PRODUCTS**,  
already has a proven track record you can trust

CONTACT A PRODUCT SPECIALIST

VISIT

[www.biopharma.co.uk](http://www.biopharma.co.uk)

# The UK's number one sealing solutions provider

Service Sealing Solutions Ltd provide a number of different sealing solutions across the UK to both the public and private sectors. As the sole UK distributor for the sealing industry's top manufacturers; DOYMA and HKD, Service Sealing Solutions Ltd specialises in high-quality service duct sealing systems for utility services and watertight seals.

Service Sealing Solutions Ltd has the exclusive rights to distribute DOYMA products in the UK. DOYMA stands on the front line when it comes to the development of innovative, practical solutions for sealing and fire systems. Providing the very best in German engineering, DOYMA is used to seal penetration points in walls and floors to permanently prevent any infiltration of gases and water into the building. All DOYMA products are designed to solve all watertight duct sealing requirements, prevent against structural damage and incorporate rubber mouldings that ensure all gas and watertight features.

Demanding building types, such as power plants, large industrial plants, reservoirs or airports, often require highly specialised

custom-made constructions. They place high demands on the fact that building penetrations such as cables and pipe work need to be permanently sealed. In the case of extraordinary pipe dimensions or special thermal, chemical or physical requirements, sealing systems in the form of a special construction are the required solution.

Service Sealing Solutions Ltd has a large range of DOYMA products that come with a 25-year warranty. DOYMA product brochures are available on the website and include products that have been supplied to some of the UK's largest projects such as HS2 and Kings Cross in London. DOYMA has recently released its new generation Curaflex Nova® gaskets, which are the perfect solution for any professional tradesman instantly looking to solve sealing problems and can be adapted to multiple applications.

Service Sealing Solutions also supplies HKD products, which are now owned by DOYMA. HKD manufacture a large range of pipe sealing systems and service conduits that are guaranteed to withstand up to four bars pressure. HKD systems have a sealing solution for service



Husband and wife team, Jim & Tina have recently visited DOYMA in Germany to find out about the innovative products that DOYMA have been developing

conduits cast into concrete without the sleeves. They are supplied and ready to use, requiring no site preparation work prior to installation. With options such as KE Socketless service conduits, KG Wall Ducts and Floor Ducts, together with KG Twin Sockets for installation in pump sumps, HKD products are ideal for situations where suitability for thin-walled concrete structures is vital.

For more information, please see below:  
T 01952 510050  
[www.servicesealingsolutions.co.uk](http://www.servicesealingsolutions.co.uk)



# Service Sealing Solutions Ltd - suppliers of DOYMA products



Service Sealing Solutions Ltd are the sole UK distributor of DOYMA products. Wherever services are installed through walls, ceilings or floors, penetrating water may cause damage to buildings. Lack of attention to the points of entry of pipes and cables into the building can have serious results: damp cellars, equipment damaged by water ingress and high repair costs. Service sealing systems ensure professional and perfect pipe sealing, thus presenting excellent preventative measures against structural damage. The very best in German engineering is used to seal penetration points to the wall to permanently prevent any infiltration of gases and water into the building, and the duct sealing systems are guaranteed for 25 years. Service Sealing Solutions supply the full range of products to suit all situations for power cables, communication cables, pipes and ducts, and specialising in sealing district heating pipes.

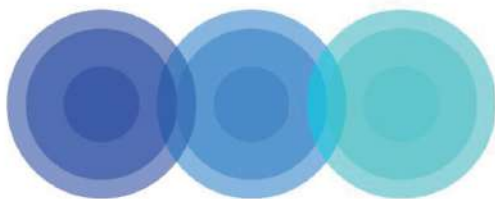

Service Sealing Solutions Ltd



**01952 510050 | [www.servicesealingsolutions.co.uk](http://www.servicesealingsolutions.co.uk)  
[sales@servicesealingsolutions.co.uk](mailto:sales@servicesealingsolutions.co.uk)**

# Direct Hoist heading to net zero

Environmental awareness isn't something you'd normally associate with the construction sector. Indeed, it's reckoned that a third of the UK's entire carbon emissions come from the built environment.



So, the industry must create and maintain a sustainable outline for the future. Direct Hoist is an ever-expanding construction hoist hire and sales specialist that is leading the field in environmental awareness.

Company founder Rob Wilson says, "Direct Hoist has spent the past three years minimising our carbon footprint, crafting a robust strategy for our Net Zero future, and pushing forward with our written policy for our Construction Line (Silver) accreditation."



Rob's approach started with the basics: long-life, low-energy LED lighting was fitted to the firm's premises to replace inefficient equipment; recycling is rigorously monitored and separated to minimise general waste; scrap materials are weighed in. Then came switching electricity supplier to a 100% renewable electricity produced by wind and solar Farms for the firm's workshops and offices, and sustainable practices throughout the entire business and favours suppliers that are either local (to cut transportation) or offer green credentials.

Direct Hoist has added a fully electric Corsa to its fleet of diesel-powered vans that run on 100% renewable HVO (hydrotreated vegetable oil) fuel, so now even a local supply run is fully renewable powered.

Of course, Direct Hoist has for years supplied electrically-powered construction hoists instead of old-fashioned engine-driven devices. Rob says, "They use a 110, 240 or 415-volt supply, depending on the lifting capacity and size of the hoist platform required, so there are no carbon (CO<sub>2</sub>), nitrogen oxide (NO<sub>x</sub>) or carbon monoxide (CO) emissions here."



Direct Hoist is also investing in lithium-ion battery-powered lifts, which can carry 120kg up to heights of 10m, controlled wirelessly by a smart-phone app. They're ideal for transportation and installation of solar panels.

Most importantly, the inclusion of a hoist on any construction site has an added environmental benefit due to its manpower-saving efficiency. Construction hoists dramatically reduce project timescales – the speed and ability of a lifting platform to take tools and materials up multiple storeys can knock weeks off a large scheme – thereby minimising workers' journeys to and from site.

Rob says, "Direct Hoist is committed to going green, and we're taking a direct route towards sustainability."

For more information, please contact the team today:  
**T 01724 781647**  
[info@directhoist.co.uk](mailto:info@directhoist.co.uk)  
[www.directhoist.co.uk](http://www.directhoist.co.uk)



# DIRECT HOIST

OFFICIAL UK DISTRIBUTOR OF

## Electroelsa

# DIRECT HOIST

EST. 2014

**01724 781647**  
**DIRECTHOIST.CO.UK**



# 75 years of W J Horrod Ltd

This year, W J Horrod Ltd, an award-winning, family-owned business, proudly celebrates 75 years!

Founded in 1950 by brothers William John and Alex Horrod, W J Horrod Ltd began as a repair service, leveraging their military engineering experience. It quickly evolved into a leading manufacturer of asphalt and bitumen equipment, as well as civil engineering and highway maintenance machinery.

Incorporated in 1961, the company was named after their father William John Horrod Snr, whose financial support made it possible. Over the years, it remained a family business, with younger brothers and later generations taking the helm. Today, second-generation directors Kim and Terry run the company, with third-generation apprenticeship to carry on the legacy.

For 75 years, W J Horrod Ltd has been at the forefront of manufacturing equipment for industrial solutions. Based in London, the company is widely recognised as the industry leader in safety and efficiency.

Horrods thrive on challenges: continually developing, designing, and testing new products to ensure customers have the very best machinery and plant for each project. Over the years, Horrods has worked across mainly the 'building' industry, but its expertise is not strictly



limited to it. The company has provided all manner of products for manual handling, with clients ranging from the Royal Opera House, to the QEII Conference centre and Billingsgate Market. Their product range is extensive, and includes everything from the SwiftMelt Mastic asphalt mixer to Hotboxes, Hot Air Rubber Materials melters, and thermoplastic pre heaters (whiteliners.)

Always at the forefront of safety, quality and efficiency, Horrods' range of services also include operator training, a

hire service for many of its products, consultation on heating/decanting of new materials, research & development for problem solving, health & safety, and the ability to collaborate with Health & Safety Executives.



Terry Horrod Snr truly championed health & safety and advised HSE on good practices until the early 2000's. Safety continues to be the watch word at Horrods today, as many of the larger products have moving parts using LPG Propane Gas or electric elements, and are heating vessels that produce hot materials.

Working alongside AYM, Horrods takes safeguarding very seriously, prioritising safety alongside quality. Every product is crafted using the highest-quality components and undergoes a rigorous design process, including longevity testing. Additionally, they ensure that products are easy to service and monitor once they leave the workshop.



For more information, please contact the team on the details below:  
**T 020 8539 5746**  
<https://www.wjhorrod.co.uk>



## 75 Years of Research & Development have allowed us to hone our expertise and to produce design and engineering excellence

W J Horrod Ltd has been manufacturing equipment for the roofing industry since the late 1950s.

Recognised as the leading manufacturer for Safety and Efficiency, Horrods is a family owned business based in London, as it has been for its 75 year existence.



2 Drum 110 Volt Electric Agitation model gas-fired

SMS Thermostat Control Bitumen Boilers



Swiftmelt Mastic & Specialist Asphalt Mixer



Safety Melt Series 4: Thermostatically Controlled Bitumen Boiler



For more information, please visit [www.wjhorrod.co.uk](http://www.wjhorrod.co.uk)  
 Contact **020 8539 8746** or email [kim@wjhorrod.co.uk](mailto:kim@wjhorrod.co.uk)



## Prefabricated Portable Buildings

# Premium prefabricated portable building blocks and more

Arkem Leisure Ltd, based in Staffordshire, are the UK's leading manufacturer and supplier of premium portable toilet and washing facilities for Campsites, Caravan Parks, Holiday Parks, Marinas, and Sports & Leisure facilities.

A clean, well-maintained toilet and shower block is a major attraction for customers seeking a comfortable 'home from home'



experience. If you're considering replacing or upgrading your current brick-built facilities, Arkem Leisure offers the expertise and creative flexibility to build according to your precise specifications. From size and colour to interior details, Arkem ensures every requirement is met - saving you both time and money. The full range of unisex showers and toilet blocks can be found on the website, and all come with optional extras.

However, Arkem Leisure doesn't just stop at toilet and shower blocks, they also create beautiful Luxury Lodges. Each Lodge can be made completely bespoke to your needs, whether you want one, two or three bedrooms, as well as elegant kitchens and living spaces featuring log burners and recessed TV screens.

**T 01543 524553**  
[info@arkemleisure.com](mailto:info@arkemleisure.com)  
<https://arkemleisure.com>



## FACILITIES TO COMPLIMENT YOUR BUSINESS

UK's #1 SUPPLIER OF PREMIUM PORTABLE TOILET & SHOWER BLOCKS



TOILET & SHOWER



ACCESSIBLE TOILET & SHOWER



TOILET ONLY



GET IN TOUCH TODAY!  
01543 524 553  
[info@arkemleisure.com](mailto:info@arkemleisure.com)  
[www.arkemleisure.com](http://www.arkemleisure.com)

## THE POSSIBILITIES ARE ENDLESS...

Each block is completely bespoke, meaning you can decide on the layout that best matches your needs.

# CAMB MACHINE KNIVES

*"A Cut Above the Rest"*

## QUALITY IS OUR GUIDING PRINCIPAL

With over 34 years of experience supplying the machine knives industry. CAMB Machine Knives was established in the UK in 1989 and aimed to provide consistently high quality knives and service to a broad range of industry sectors. Based on these guiding principals, CAMB Machine Knives has flourished and grown throughout Europe, USA in 25 countries worldwide establishing a reputation for high quality products and service.

## CAMB MACHINE KNIVES INTERNATIONAL REACH

CAMB Knives International really does have an international reach with a network of exporters and carriers - with offices both in the UK along with agents in Spain, Netherlands, Italy, Germany, South Africa and many more so you'll never be far away from a CAMB Knives representative.



## KNIVES FOR INDUSTRY - WE'LL SUPPLY IT

Our range includes many types of blades, but not limited to:

**CIRCULAR KNIVES**

**GRANULATOR KNIVES**

**POULTRY KNIVES**

**RAZOR BLADE KNIVES**

**STRAIGHT KNIVES**

**TOOTHED KNIVES**

**TRAY FORM KNIVES**

**TOP/BOTTOM KNIVES**

**ZIG ZAG KNIVES**

### **CAMB MACHINE KNIVES INTERNATIONAL LTD**

Tel: 01454 322178 | Fax: 01454 321172

Email: [sales@Camb-knives.co.uk](mailto:sales@Camb-knives.co.uk)

[www.Camb-knives.co.uk](http://www.Camb-knives.co.uk)

MANUFACTURERS AND DISTRIBUTORS OF MACHINE KNIVES TO ALL INDUSTRIES



# Machinery Supplies UK Ltd

## Leading laser welding and laser cleaning technology

Laser welding machines are used to join thin metal sheets with minimum heat input and the joining of differing metals, offering precision advantages for intricate designs and delicate materials.

During 2023, the global laser welding machine market grew exponentially to \$1.32 billion from \$1.26 billion the year before, with a projected growth of \$1.55 billion by 2027. Europe has seen the biggest share of the market, closely followed by growing interest across the Asia-Pacific region.

There is increasing global demand for fabricated metal products in the renewable energy sector (wind turbine manufacturing), automotive (engine parts to injectors), aerospace, medical, electronics sectors (circuit boards, transistors and integrated circuits) and jewellery/the arts.

With a focus on the circular economy and Net Zero Targets, laser welding provides pinpoint accuracy, which means higher quality welds and less waste.



### Spotlight on Machinery Supplies UK Ltd: Laser welding experts

Laser welding is a game-changer, offering welding up to four times faster than TIG welding, with significantly greater safety assurances due to reduced splatter and debris.

Established in 2020, Machinery Supplies UK Ltd was founded by Andy Naylor, who brings a wealth of industrial sheet metal experience spanning over 35 years. Based in East Yorkshire, Andy regularly travels to China to source the world's best laser welding machinery from high-end manufacturers to sell to clients in the UK, Europe, USA and Taiwan.

### Laser welding: The future is here

Laser welding is ten times faster than conventional welding, which is good news for capacity and high demand in sectors like wind turbine manufacturing. The new Labour Government has removed restrictions on on-shore wind turbine planning and plans to deliver 50GW of offshore wind by 2030. This translates to the building of 2,600 wind turbines at the cost of £48 million by 2030 alone. Due to its geographical location, the UK has more capacity for offshore wind power generation compared to any other country in the world, except China. Laser welding offers hugely advantageous benefits to welding across the wind turbine manufacturing sector, which in turn will transform the UK's renewable energy sector.

### Contact us today for the latest available fiber lasers

We have meticulously tested all duty cycles and penetration levels and they are all coupled with auto single or double wire feed, with water-cooled refrigerant, with superior components like refrar laser

guns and maxphotonics. Our latest upgrades have nozzle changes to allow laser weld cleaning functions.

We can provide all information on machinery requirements, have a full UK stock of spares and consumables, expert welding technician phone support and arrange delivery as required and our laser cleaning technology is second to none.

### Laser cleaning technology

Laser cleaning technology is used in variety of applications, to remove rust, paint, oxide and other contaminant like graffiti - with no damage to materials, due to its eco-friendly properties. This is an industry game-changer that substitutes sand blasting and other ways of cleaning metals. Traditional industrial cleaning methods are labour-intensive and some paint removal by sandblasting has caused permanent damage to the metal beneath.

### Endnote on Laser welding

Laser welding is used for welding components made from high-strength alloys in aerospace, creating precise joins in surgical instruments in medical science, is integral to wind turbine manufacturing and many more applications. It is transforming manufacturing, repair and design on a global scale.

### Visit the East Yorkshire showroom today!

For more information, contact Andy Naylor on the details below:

T 01482 420491

T 07743 989565

info@ukmachinery.uk

https://ukmachinery.uk

https://www.linkedin.com/in/andy-n-629859a0

https://twitter.com/usedmach

## QUALITY FABRICATION MACHINERY



### We offer full UK support and training

- Laser Welding
- Laser Cleaning
- Laser Engraving
- Laser Cutting
- Laser Accessories/Slat Cleaners
- Breakout Hammers - Magnet Lifters
- Pressbrakes - Shears - Punching
- UK Stock Consumables - UK Engineers



Please visit: [machinesupplies.co.uk](http://machinesupplies.co.uk)

M. 07743 989565 | T. 01482 420491 | E. info@ukmachinery.uk



# Hat-trick Award for Davies Turner Group

For the third successive year, the Davies Turner Group have been presented with an internationally-recognised award by the Royal Society for the Prevention of Accidents, RoSPA Gold Award, further solidifying this company's position as a worldwide freight and logistics partner.

Davies Turner provides pioneering direct UK weekly rail services in conjunction with their long-term partner in China, Air Sea Transport, who has years of experience in the China rail sector.

Since 2016, Davies Turner have operated China to UK rail services for full load (FCL) and groupage (LCL) shipments, assisting clients with their supply chain needs by reducing shipping times in comparison to Sea Freight. The availability of their import rail services has been vital to clients since the advent of the pandemic, where many importers witnessed shipping line ocean transit time delays, port delays and air freight became cost prohibitive for many large volume or dense cargo shipments.

With confidence and demand for China rail freight services soaring, as evidenced by the 50,000th China-Europe intermodal train embarking on its journey towards the west at the beginning of February this year, Davies Turner have introduced and support a dedicated weekly eastbound rail service for LCL cargo, having undertaken successful trials.



Established over 150 years ago and as one of the first companies in Europe to become accredited as a Full Authorised Economic Operator, this forward-thinking company is now a bona fide international freight forwarder, with an award-winning pedigree.

The group has 15 UK branches, including a head office in Birmingham.

We caught up with Andrew Ford, Branch Manager in Rotherham, Yorkshire to find out more, "The Rotherham branch specialises in awkward and out-of-gauge shipments, shipping many vehicles ranging in sizes and type to small rail engines as well as large machinery moves around the world. Alongside this they offer standard freight forwarding – which means the Rotherham Branch can assist in almost all enquiries they receive: 'from an envelope to a large project.'"

"We have an extensive knowledge of the services that we offer within our branch, with our dedication to detail to ensure where possible shipments smoothly and clients are updated should there be any delays out-of-our-control."



"We have had a good start to this fiscal year, which was surprising with the current downturn in world trade. Our short-term plan is to improve our office environment with some renovations and also look at team building activities that had to be suspended throughout COVID. We are also looking at more training for our staff so they can gain even more experience and knowledge to help assist our clients."

Despite most of the COVID-pandemic restrictions lifting and shipping costs starting to decrease, the world of international freight still has to contend with the challenges posed by the war in Ukraine, port strikes and a near-global recession.

Davies Turner offers a light at the end of a gloomy tunnel with its express freight rail service and its extensive European overland portfolio with direct groupage, part load and full load trailer services. Customers can choose between express transit and super-express options, in a thoroughly streamlined system.

**For all transportation quotations and further information, please see the details below:**  
**T 01709 529709**  
**rotherhamsales@daviesturner.co.uk**  
**www.daviesturner.com**



## Biogas & Ventilation



Specialising in quality equipment for tank storage, process safety, and fluid transfer, we offer dedicated maintenance and expert technical support. Rooted in our commitment to you and the environment, we champion emission reduction and quantification, merging efficiency with ecological accountability.

**T +44 (0)1726 844707**  
**info@assentech.co.uk**  
**www.assentech.co.uk**

## Farming



A small 18-acre working family farm in the market town of Oakham, the county town of Rutland, England's smallest county.

**T 01572 722122**  
**admin@rutlandfarmpark.co.uk**  
**www.rutlandfarmpark.co.uk**

## Roofing



We have been at the forefront to design, innovate and manufacture materials and products to make buildings and flat roofs watertight. As the world above and below the roof is constantly changing, so do we to adapt and offer sustainable, durable and easy-to-install roofing and facade systems.

**T +44 (0)1623 627285**  
**info.uk@ccm-europe.com**  
**www.ccm-europe.com/gb**

## UK Machinery



Machine Operators – Software Engineers  
 – Electronic and Hydraulic Engineers

We have an excellent skill force and team to back up our sales with 24/7 Support Network.

Over 35 Years of experience.

**T 01482 420491**  
**info@ukmachinery.uk**  
**www.ukmachinery.uk**

## Marine, Offshore, Chemical, Oil & Gas



MiB is a product/service that builds in diagnostic support for multiple assets via Machine Learning and Artificial Intelligence.

**T +44 (0)7422 079140**  
**simon.edmondson@**  
**cmservicesglobal.co.uk**  
**maintenance-in-balance.com**

## Noise & Vibration Measurement



We manufacture and supply high-quality acoustic measurement instrumentation. Cirrus Research is dedicated to the prevention and eradication of noise-induced hearing loss and environmental noise pollution.

**T +44 (0)1723 891655**  
**https://cirrusresearch.com**



## Metal Improvements



Curtiss-Wright surface technologies provides customers a single-source solution and point of contact for all their controlled material surface treatments, supporting their requirements through our global network of over 70 worldwide facilities and on-site field teams, improving and reducing turnaround times and costs.

**T +44 (0)1635 279621**  
**eurosales@cwst.com**  
**www.cwst.co.uk**

## Industrial Applications

Working with light since 1931, CML is the market leader in the field of miniature lighting for signalisation. As one of the first companies to introduce LED lamps, nearly 30 years ago, CML is now the supplier with the broadest range of miniature lighting products in the world.

**T +44 (0)1284 714700**  
**uksales@cml-it.com**  
**https://cml-it.com/en**

## Ocean Power & Monitoring Systems



With more than 15 years of experience, SubCtech has established its position among leading manufacturers for Ocean Power and Monitoring systems.

**T +49 (0)431 220 39880**  
<https://subctech.com>

## Air Pollution Control Systems



Providing specialist industrial air pollution control, gas treatment and odour control packages – turnkey supply of the complete system: design, supply, installation and commissioning – all backed by a process guarantee.

**T 01403 290000**  
[info@ergapc.co.uk](mailto:info@ergapc.co.uk)  
[www.ergapc.co.uk](http://www.ergapc.co.uk)

## Deep Hole Drilling



Our industry-leading customers around the world rely on UNISIG® deep hole drilling technologies for powerful, productive solutions and value. We engineer our machines to handle a complete range of applications, and support them with our high level of expertise and service.

**T +49 (0)7125 9687590**  
<https://unisig.com>

## Electrical Products



The SIMONBOX IP66 watertight floor box is designed for use in hard floor areas which require occasional power and data connection and an IP protection rating. Typical ip66 waterproof floor box installations include Department Stores, Airports, Train Stations and Car showrooms.

**T 0203 286 7949**  
[simonbox.co.uk](http://simonbox.co.uk)

## Sealing Solutions



Service Sealing Solutions are the sole UK distributor for the sealing industry's top manufacturers; DOYMA and HKD.

**Contact**  
**T 01952 510050**  
[www.servicesealingsolutions.co.uk](http://www.servicesealingsolutions.co.uk)

## Measurement Applications



Interface Force Measurements Ltd is the master distributor for Interface load cells in the UK, Ireland, Middle East and North Africa. While we are separate companies, our interests and values are closely aligned in a long-term commercial relationship spanning over 30 years.

**T +44 (0)1344 776666**  
[interfaceforce.co.uk](http://interfaceforce.co.uk)

## Emission Monitoring & Gas Control



ECO PHYSICS AG offers innovative analytical solutions for measurement tasks in the fields of environment, health and process control.

**T +41 55 220 22 22**  
[info@ecophysics.com](mailto:info@ecophysics.com)  
[www.ecophysics.com](http://www.ecophysics.com)

## Hand Protection



Manosun hand protection want to bring a change to the end-user experience in selecting and buying industrial gloves, gauntlets and sleeves (PPE).

**Contact**  
**T +44 (0)191 300 8699**  
[sales@manosun.co.uk](mailto:sales@manosun.co.uk)  
[www.manosun.co.uk](http://www.manosun.co.uk)



Rutland Farm Park is a small 18-acre working farm in the market town of Oakham, the county town of Rutland, England's smallest county.

We are open all year round for you and your family to explore our tracks and meet and feed our wonderful and friendly animals.

**Admission Prices**  
**Farm Park Admission**

Adult 13+	£10
Child 3-12	£9
Under 3	Free
Family ticket	£35.00
Visitor with support needs with carer	£15

*(2 Adults and 2 Children/1 Adult and 3 Children)*  
*We offer 10% Military discount with a valid ID*  
*(Annual Passes Available)*

**Opening Times**  
**Summer**

Tuesday - Sunday 10am-5pm  
(Last entry at 4:00pm)

**Winter**

Open on Bank Holiday Mondays  
and School Holidays  
Closed Christmas Day and New Years Day



Please visit [www.rutlandfarmpark.co.uk](http://www.rutlandfarmpark.co.uk),  
contact **01572 722122** or  
email [info@rutlandfarmpark.co.uk](mailto:info@rutlandfarmpark.co.uk)

